

## **Module 5: Theories of Failure**

### **Objectives:**

Various types of theories of failure and its importance

### **Learning Structure**

- 5.0 Introduction
- 5.1 Stress-Strain relationships
- 5.2 Types of Failure
- 5.3 Use of factor of safety in design
- 5.4 Theories of Failure
- 5.5 Problems
- Outcomes
- Further reading

## 5.0 Introduction:

Failure indicate either fracture or permanent deformation beyond the operational range due to yielding of a member. In the process of designing a machine element or a structural member, precautions has to be taken to avoid failure under service conditions.

When a member of a structure or a machine element is subjected to a system of complex stress system, prediction of mode of failure is necessary to involve in appropriate design methodology. Theories of failure or also known as failure criteria are developed to aid design.

### 5.1 Stress-Strain relationships:

Following Figure-1 represents stress-strain relationship for different type of materials.

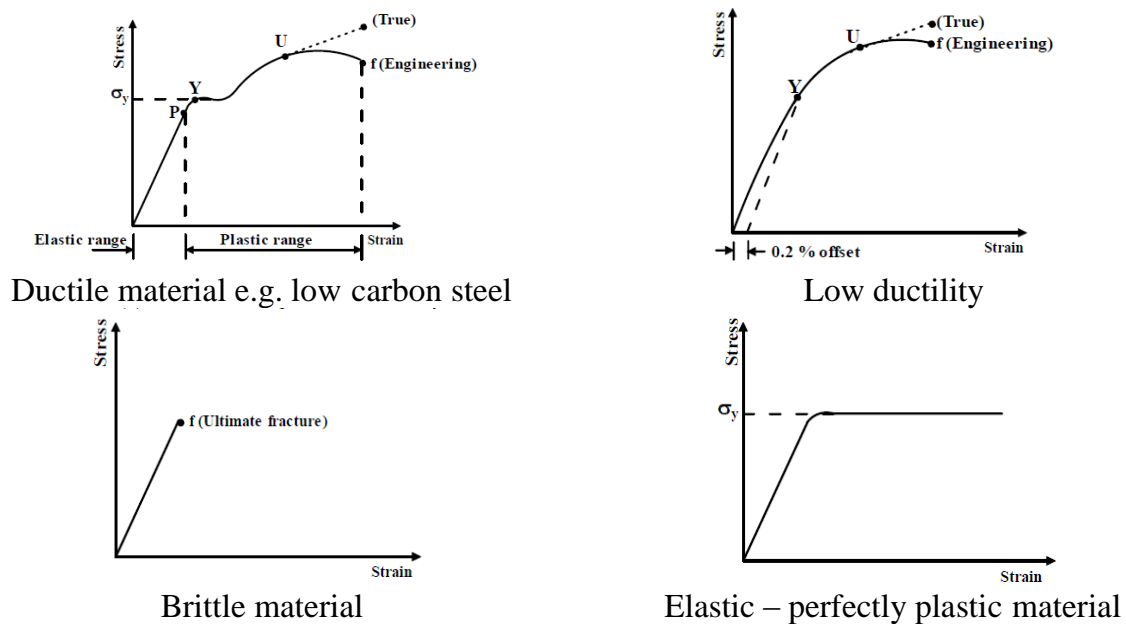

Figure-: Stress-Strain Relationship

Bars of ductile materials subjected to tension show a linear range within which the materials exhibit elastic behaviour whereas for brittle materials yield zone cannot be identified. In general, various materials under similar test conditions reveal different behaviour. The cause of failure of a ductile material need not be same as that of the brittle material.

## **5.2   Types of Failure:**

The two types of failure are,

**Yielding** - This is due to excessive inelastic deformation rendering the structural member or machine part unsuitable to perform its function. This mostly occurs in ductile materials.

**Fracture** - In this case, the member or component tears apart in two or more parts. This mostly occurs in brittle materials.

## **5.3   Use of factor of safety in design:**

In designing a member to carry a given load without failure, usually a factor of safety (FS or N) is used. The purpose is to design the member in such a way that it can carry N times the actual working load without failure. Factor of safety is defined as Factor of Safety (FS) = Ultimate Stress/Allowable Stress.

## **5.4   Theories of Failure:**

- a) Maximum Principal Stress Theory (Rankine Theory)
- b) Maximum Principal Strain Theory (St. Venant's theory)
- c) Maximum Shear Stress Theory (Tresca theory)
- d) Maximum Strain Energy Theory (Beltrami's theory)

### **5.4.1   Maximum Principal Stress Theory (Rankine theory)**

According to this, if one of the principal stresses  $\sigma_1$  (maximum principal stress),  $\sigma_2$  (minimum principal stress) or  $\sigma_3$  exceeds the yield stress ( $\sigma_y$ ), yielding would

occur. In a two dimensional loading situation for a ductile material where tensile and compressive yield stress are nearly of same magnitude

$$\sigma_1 = \pm \sigma_y \quad \sigma_2 = \pm \sigma_y$$

Yield surface for the situation is, as shown in Figure-2

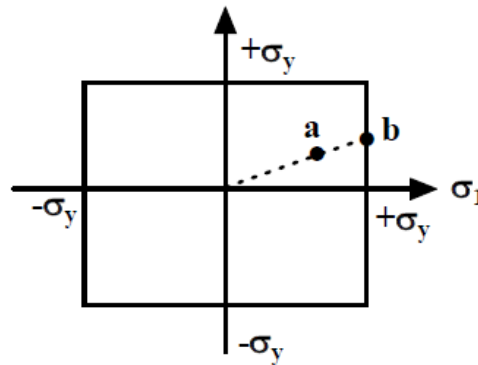

Figure- 2: Yield surface corresponding to maximum principal stress theory

Yielding occurs when the state of stress is at the boundary of the rectangle. Consider, for example, the state of stress of a thin walled pressure vessel. Here  $\sigma_1 = 2\sigma_2$ ,  $\sigma_1$  being the circumferential or hoop stress and  $\sigma_2$  the axial stress. As the pressure in the vessel increases, the stress follows the dotted line. At a point (say) a, the stresses are still within the elastic limit but at b,  $\sigma_1$  reaches  $\sigma_y$  although  $\sigma_2$  is still less than  $\sigma_y$ . Yielding will then begin at point b. This theory of yielding has very poor agreement with experiment. However, this theory is being used successfully for brittle materials.

### **5.4.2 Maximum Principal Strain Theory (St. Venant's Theory)**

According to this theory, yielding will occur when the maximum principal strain just exceeds the strain at the tensile yield point in either simple tension or compression. If  $\epsilon_1$  and  $\epsilon_2$  are maximum and minimum principal strains corresponding to  $\sigma_1$  and  $\sigma_2$ , in the limiting case

$$\epsilon_1 = (1/E)(\sigma_1 - \nu\sigma_2) \quad |\sigma_1| \geq |\sigma_2|$$

$$\varepsilon_2 = (1/E)(\sigma_2 - \nu\sigma_1) \quad |\sigma_2| \geq |\sigma_1|$$

This results in,

$$E \varepsilon_1 = \sigma_1 - \nu\sigma_2 = \pm \sigma_0$$

$$E \varepsilon_2 = \sigma_2 - \nu\sigma_1 = \pm \sigma_0$$

The boundary of a yield surface in this case is shown in Figure – 3.

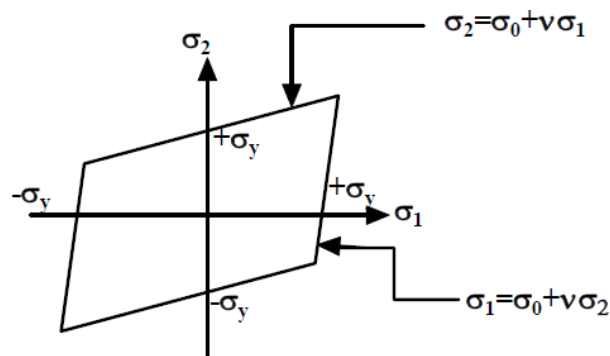

Figure-3: Yield surface corresponding to maximum principal strain theory

### **5.4.3 Maximum Shear Stress Theory (Tresca theory)**

According to this theory, yielding would occur when the maximum shear stress just exceeds the shear stress at the tensile yield point. At the tensile yield point  $\sigma_2 = \sigma_3 = 0$  and thus maximum shear stress is  $\sigma_y/2$ . This gives us six conditions for a three-dimensional stress situation:

$$\sigma_1 - \sigma_2 = \pm \sigma_y$$

$$\sigma_2 - \sigma_3 = \pm \sigma_y$$

$$\sigma_3 - \sigma_1 = \pm \sigma_y$$

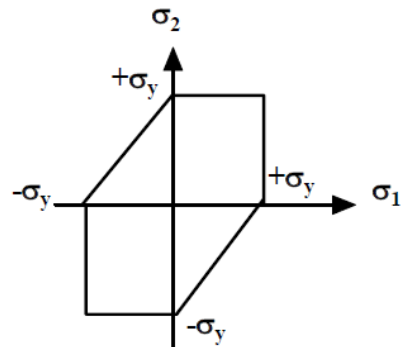

Figure – 4: Yield surface corresponding to maximum shear stress theory

In a biaxial stress situation (Figure - 4) case,  $\sigma_3 = 0$  and this gives

$$\begin{array}{ll}
 \sigma_1 - \sigma_2 = \sigma_y & \text{if } \sigma_1 > 0, \sigma_2 < 0 \\
 \sigma_1 - \sigma_2 = -\sigma_y & \text{if } \sigma_1 < 0, \sigma_2 > 0 \\
 \sigma_2 = \sigma_y & \text{if } \sigma_2 > \sigma_1 > 0 \\
 \sigma_1 = -\sigma_y & \text{if } \sigma_1 < \sigma_2 < 0 \\
 \sigma_1 = -\sigma_y & \text{if } \sigma_1 > \sigma_2 > 0 \\
 \sigma_2 = -\sigma_y & \text{if } \sigma_2 < \sigma_1 < 0
 \end{array}$$

This criterion agrees well with experiment.

In the case of pure shear,  $\sigma_1 = -\sigma_2 = k$  (say),  $\sigma_3 = 0$  and this gives  $\sigma_1 - \sigma_2 = 2k = \sigma_y$

This indicates that yield stress in pure shear is half the tensile yield stress and this is also seen in the Mohr's circle (Figure - 5) for pure shear.

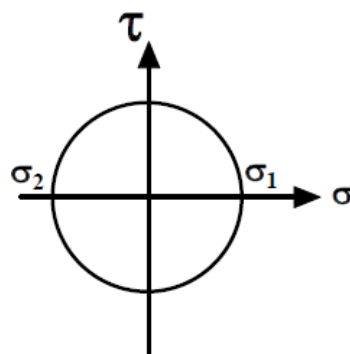

Figure – 5: Mohr's circle for

pure shear

#### 5.4.4 Maximum strain energy theory (Beltrami's theory)

According to this theory failure would occur when the total strain energy absorbed at a point per unit volume exceeds the strain energy absorbed per unit volume at the tensile yield point. This may be expressed as,

$$(1/2)(\sigma_1 \varepsilon_1 + \sigma_2 \varepsilon_2 + \sigma_3 \varepsilon_3) = (1/2) \sigma_y \varepsilon_y$$

Substituting  $\varepsilon_1, \varepsilon_2, \varepsilon_3$  and  $\varepsilon_y$  in terms of the stresses we have

$$\sigma_1^2 + \sigma_2^2 + \sigma_3^2 - 2\nu(\sigma_1 \sigma_2 + \sigma_2 \sigma_3 + \sigma_3 \sigma_1) = \sigma_y^2$$

$$(\sigma_1/\sigma_y)^2 + (\sigma_2/\sigma_y)^2 - 2\nu(\sigma_1 \sigma_2/\sigma_y^2) = 1$$

The above equation represents an ellipse and the yield surface is shown in Figure - 6

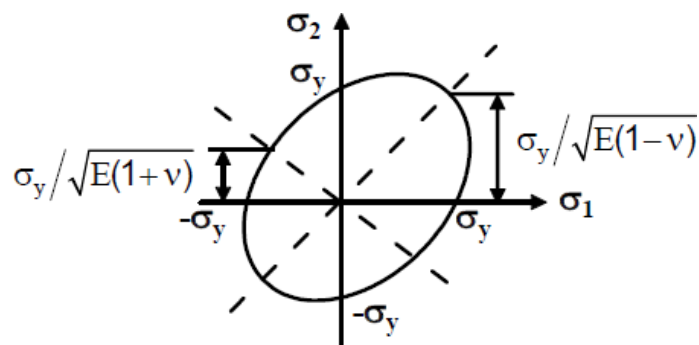

Figure – 6: Yield surface corresponding to Maximum strain energy theory.

It has been shown earlier that only distortion energy can cause yielding but in the above expression at sufficiently high hydrostatic pressure  $\sigma_1 = \sigma_2 = \sigma_3 = \sigma$  (say), yielding may also occur. From the above we may write  $\sigma^2(3 - 2\nu) = \sigma_y^2$  and if  $\nu \sim 0.3$ , at stress level lower than yield stress, yielding would occur. This is in contrast to the experimental as well as analytical conclusion and the theory is not appropriate.

### 5.4.5 Superposition of yield surfaces of different failure theories:

A comparison among the different failure theories can be made by superposing the yield surfaces as shown in figure – 7. It is clear that an immediate assessment of failure probability can be made just by plotting any experimental in the combined yield surface. Failure of ductile materials is most accurately governed by the distortion energy theory where as the maximum principal strain theory is used for brittle materials.

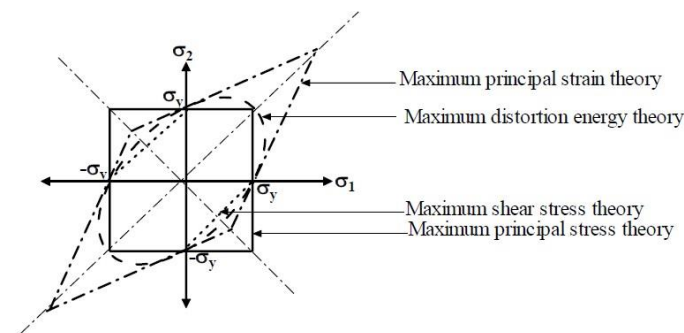

Figure – 7: Comparison of different failure theories

### 5.5 Problems:

**Numerical-1:** A shaft is loaded by a torque of 5 KN-m. The material has a yield point of 350 MPa. Find the required diameter using Maximum shear stress theory. Take a factor of safety of 2.5.

Torsional Shear Stress,  $\tau = 16T/\pi d^3$ , where d represents diameter of the shaft

Maximum Shear Stress theory,  $\sqrt{\quad}$

Factor of Safety (FS) = Ultimate Stress/Allowable Stress

Since  $\sigma_x = \sigma_y = 0$ ,  $\tau_{\max} = 25.46 \times 10^3/d^3$

Therefore  $25.46 \times 10^3/d^3 = \sigma_y/(2 \cdot \text{FS}) = 350 \cdot 10^6/(2 \cdot 2.5)$

Hence,  $d = 71.3 \text{ mm}$



**Numerical-2:** The state of stress at a point for a material is shown in the following figure Find the factor of safety using (a) Maximum shear stress theory Take the tensile yield strength of the material as 400 MPa.

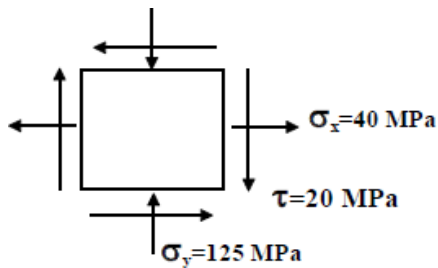

From the Mohr's circle shown below we determine,

$$\sigma_1 = 42.38 \text{ MPa and}$$

$$\sigma_2 = -127.38 \text{ MPa}$$

from Maximum Shear Stress theory

$$(\sigma_1 - \sigma_2)/2 = \sigma_y / (2 * FS)$$

By substitution and calculation factor of safety  $FS = 2.356$

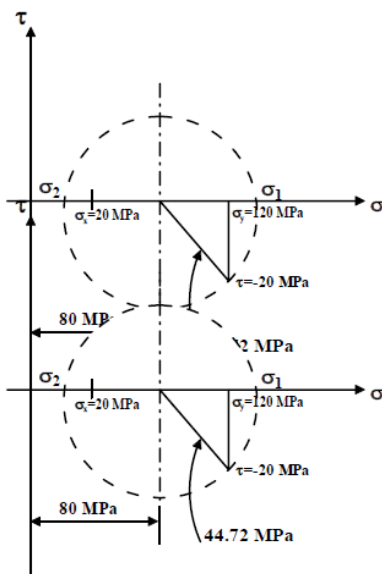

**Numerical-3:** A cantilever rod is loaded as shown in the following figure. If the tensile yield strength of the material is 300 MPa determine the

rod diameter using (a) Maximum principal stress theory (b) Maximum shear stress theory

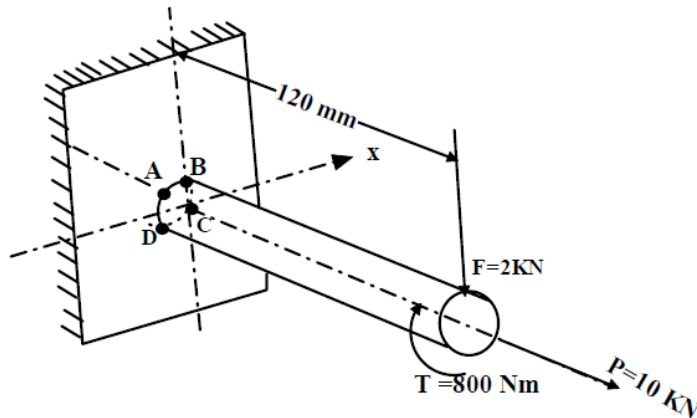

At the outset it is necessary to identify the mostly stressed element. Torsional shear stress as well as axial normal stress is the same throughout the length of the rod but the bearing stress is largest at the welded end. Now among the four corner elements on the rod, the element A is mostly loaded as shown in following figure

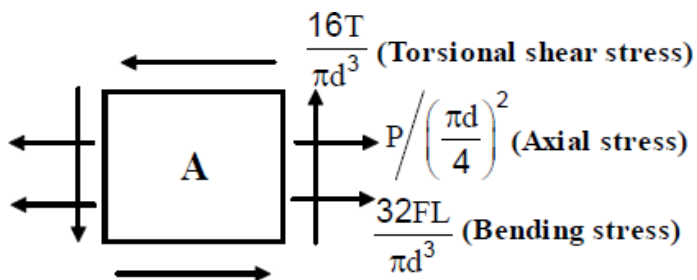

Shear stress due to bending  $VQ/It$  is also developed but this is neglected due to its small value compared to the other stresses. Substituting values of T, P, F and L, the elemental stresses may be shown as in following figure.

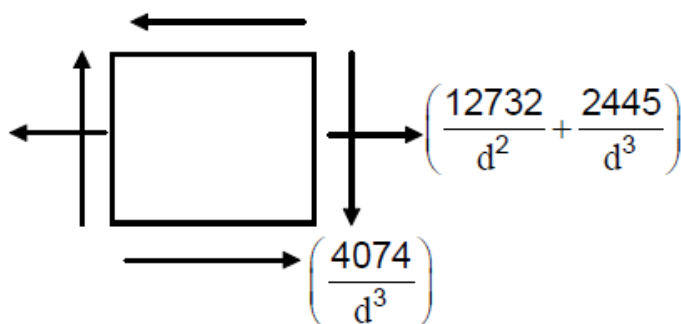

The principal stress for the case is determined by the following equation,

$$\sigma_{1,2} = \frac{1}{2} \left( \frac{12732}{d^2} + \frac{2445}{d^3} \right) \pm \sqrt{\frac{1}{4} \left( \frac{12732}{d^2} + \frac{2445}{d^3} \right)^2 + \left( \frac{4074}{d^3} \right)^2}$$

By Maximum Principal Stress Theory, Setting,  $\sigma_1 = \sigma_y$  we get  $d = 26.67\text{mm}$

By maximum shear stress theory by setting  $(\sigma_1 - \sigma_2)/2 = \sigma_y/2$ , we get,  $d = 30.63\text{mm}$

**Numerical-4:** The state of plane stress shown occurs at a critical point of a steel machine component. As a result of several tensile tests it has been found that the tensile yield strength is  $\sigma_y=250\text{MPa}$  for the grade of steel used. Determine the factor of safety with respect to yield using maximum shearing stress criterion.

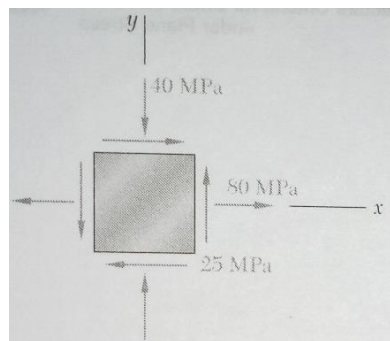

Construction of the Mohr's circle determines

$$\sigma_{\text{avg}} = \frac{1}{2} (80-40) = 20\text{MPa} \quad \text{and} \quad \tau_m = (60^2 + 25^2)^{1/2} = 65\text{MPa}$$

$$\sigma_a = 20 + 65 = 85 \text{ MPa} \quad \text{and} \quad \sigma_b = 20 - 65 = -45 \text{ MPa}$$

The corresponding shearing stress at yield is  $\tau_y = \frac{1}{2} \sigma_y = \frac{1}{2} (250) = 125\text{MPa}$

$$\text{Factor of safety, } FS = \tau_m / \tau_y = 125/65 = 1.92$$

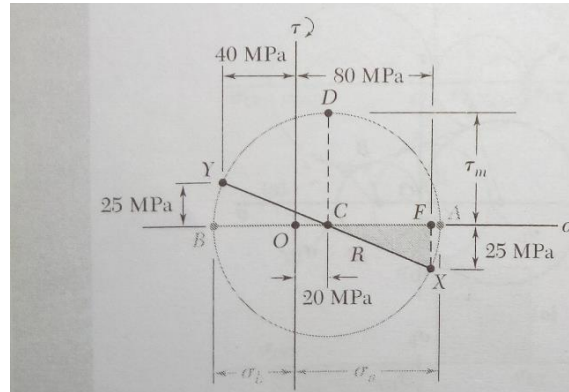

### Summary:

Different types of loading and criterion for design of structural members/machine parts subjected to static loading based on different failure theories have been discussed. Development of yield surface and optimization of design criterion for ductile and brittle materials were illustrated.

### Assignments:

**Assignment-1:** A Force  $F = 45,000\text{N}$  is necessary to rotate the shaft shown in the following figure at uniform speed. The crank shaft is made of ductile steel whose elastic limit is  $207,000\text{ kPa}$ , both in tension and compression. With  $E = 207 \times 10^6\text{ kPa}$  and  $\nu = 0.25$ , determine the diameter of the shaft using maximum shear stress theory, using factor of safety = 2. Consider a point on the periphery at section A for analysis (**Answer,  $d = 10.4\text{ cm}$** )

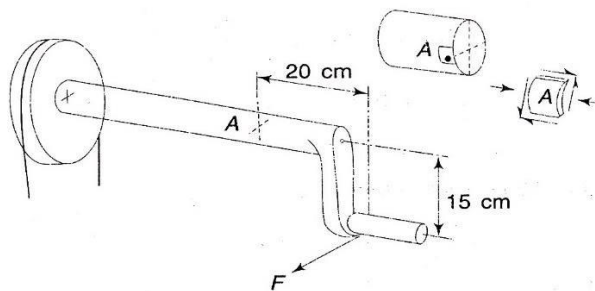

**Assignment-2:** Following figure shows three elements a, b and c subjected to different states of stress. Which one of these three, do you think will yield first according to i) maximum stress theory, ii) maximum strain theory, and iii) maximum shear stress theory? Assume Poisson's ratio  $\nu = 0.25$  [**Answer: i) b, ii) a, and iii) c**]

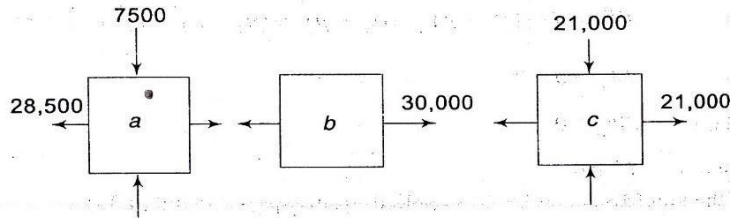

**Assignment-3:** Determine the diameter of a ductile steel bar if the tensile load  $F$  is 35,000N and the torsional moment  $T$  is 1800N.m. Use factor of safety = 1.5.  $E = 207 \cdot 10^6 \text{kPa}$  and  $\sigma_{yp} = 207,000 \text{kPa}$ . Use the maximum shear stress theory. **(Answer:  $d = 4.1 \text{cm}$ )**

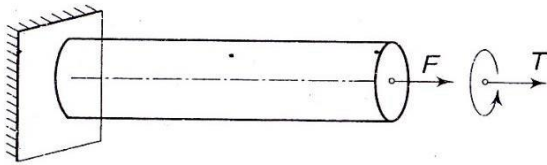

**Assignment-4:** At a point in a steel member, the state of stress shown in Figure. The tensile elastic limit is 413.7kPa. If the shearing stress at a point is 206.85kPa, when yielding starts, what is the tensile stress  $\sigma$  at the point according to maximum shearing stress theory? **(Answer: Zero)**

