

Module 5

ANTENNA TYPES

5.0	Introduction
5.1	Objective
5.2	Helical antenna
5.3	Yagi-Uda array
5.4	Corner Reflector
5.5	Parabolic Reflector
5.6	Log Periodic antenna
5.7	Lens antennas
5.8	Antennas for Special applications
5.9	Outcomes
5.10	Questions
5.11	Further Readings

5.1 INTRODUCTION

This unit describes about antenna types and their application. Types of antenna like horn antenna, helical antenna, Yagi-Uda array antenna, Log periodic antenna, reflector antennas, lens antenna are discussed. This unit also deals with the characteristics of each type of antenna and antenna application.

5.2 Objective

- To learn different types of antennas
- To learn the procedure to calculate different parameters of antennas.

5.3 Helical antenna

A helical antenna is a specialized antenna that emits and responds to electromagnetic fields with rotating (circular)polarization. These antennas are commonly used at earth-based stations in satellite communications systems. This type of antenna is designed for use with an unbalanced feed line such as coaxial cable. The center conductor of the cable is connected to the helical element, and the shield of the cable is connected to the reflector.

To the casual observer, a helical antenna appears as one or more "springs" or helixes mounted against a flat reflecting screen. The length of the helical element is one wavelength or greater. The reflector is a circular or square metal mesh or sheet whose cross dimension (diameter or edge) measures at least $3/4$ wavelength. The helical element has a radius of $1/8$ to $1/4$ wavelength, and a

pitch of 1/4 to 1/2 wavelength. The minimum dimensions depend on the lowest frequency at which the antenna is to be used. If the helix or reflector is too small (the frequency is too low), the efficiency is severely degraded. Maximum radiation and response occur along the axis of the helix.

The most popular helical antenna (often called a 'helix') is a travelling wave antenna in the shape of a corkscrew that produces radiation along the axis of the helix. These helices are referred to as axial-mode helical antennas. The benefits of this antenna is it has a wide bandwidth, is easily constructed, has a real input impedance, and can produce circularly polarized fields. The basic geometry is shown in Figure

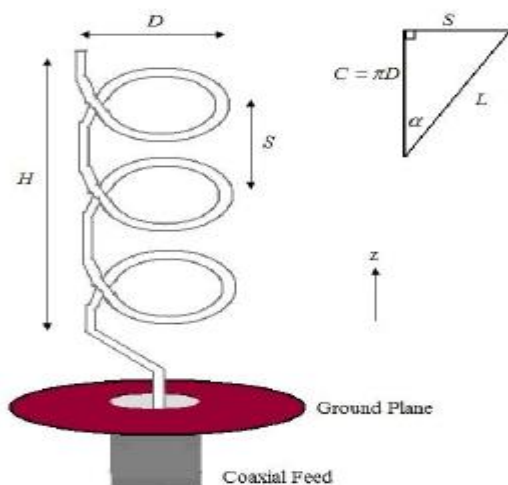
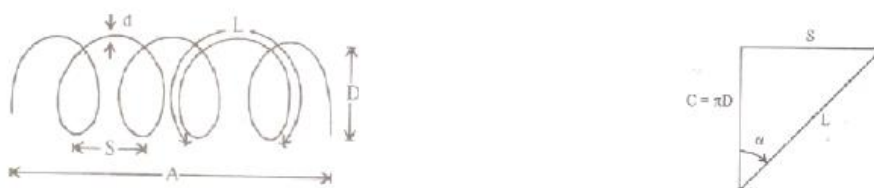

Fig 5.1 Geometry of Helical Antenna.



The helix parameters are related by

$$(\pi D)^2 = L^2 - S^2$$

Let S = Spacing between each turns

N= No. of Turns

D= Diameter of the helix

L'=A=Ns=Total length of the antenna

L= Length of the wire between each turn = $\sqrt{(\pi D)^2 + s^2}$

L_n = LN = Total length of the wire

C = πD = Circumference of the helix

α = Pitch angle formed by a line tangent to the helix wire and a plane perpendicular to the helix

axis.

$$\alpha = \tan^{-1} \frac{S}{C} = \tan^{-1} \frac{S}{\pi D}$$

Fig 5.2 Helix Structure

The radiation characteristics of the antenna can be varied by controlling the size of its geometrical properties compared to the wavelength.

Mode of Operation

- o Normal Mode
- o Axial Mode

Normal Mode:

If the circumference, pitch and length of the helix are small compared to the wavelength, so that the current is approximately uniform in magnitude and phase in all parts of the helix, the normal mode of radiation is excited.

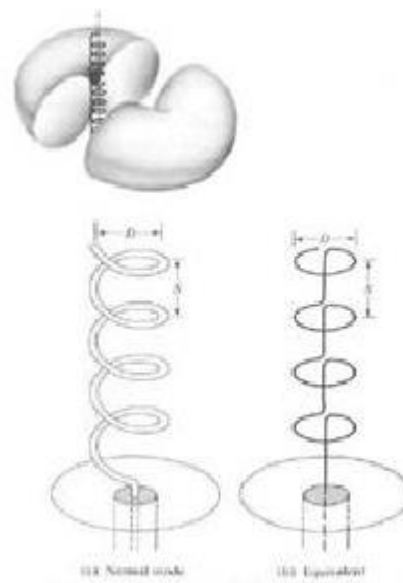

Fig 5.3 Normal Mode

In normal mode as shown in Fig 5.3 the radiation is maximum in the plane normal to the helix axis. The radiation may be elliptically or circularly polarized depending upon helix dimensions.

Disadvantages:

- o Narrow Bandwidth
- o Poor Efficiency

The radiation pattern in this mode is a combination of the equivalent radiation from a short dipole positioned along the axis of the helix and a small co-axial loop. The radiation pattern of these two equivalent radiators is the same with the polarization at right angles and the phase angle at a given point in space is at 90° apart. Therefore, the radiation is either elliptically polarized or circularly polarized depending upon the field strength ratio of the two components. This depends on the pitch

angle α . When ' α ' is very small, the loop type of radiation predominates, when it becomes very large, the helix becomes essentially a short dipole. In these two limiting cases the polarization is linear. For intermediate value of the polarization is elliptical and at a particular value of ' α ' the polarization is circular

Analysis of normal mode:

Field due to short dipole is given by

$$E_{\theta}(\theta) = \frac{j60\pi s \sin \theta}{\lambda r}$$

Field of a small loop

$$E_{\phi}(\theta) = \frac{j60\pi^2 I A \sin \theta}{\lambda^2 r}$$

Magnitude of $E_{\theta}(\theta)$ and $E_{\phi}(\theta)$ ratio defines axial ratio

$$\text{Axial ratio} = \frac{|E_{\theta}|}{|E_{\phi}|} = \frac{s\lambda}{2\pi A} = \frac{s}{\beta A}$$

The field is circularly polarized if $S = \beta A$

$$\therefore s = \frac{2\pi}{\lambda} \frac{\pi D^2}{4} = \frac{(\pi D)^2}{2\lambda}$$

$$\frac{2s}{\lambda} = \left(\frac{\pi D}{\lambda}\right)^2 \text{ From figure 6.1 } L^2 - s^2 = (\pi D)^2$$

$$\therefore \left(\frac{L}{\lambda}\right)^2 - \left(\frac{s}{\lambda}\right)^2 = \left(\frac{\pi D}{\lambda}\right)^2 = \frac{2s}{\lambda}$$

$$1 + \left(\frac{L}{\lambda}\right)^2 = 1 + \frac{2s}{\lambda} + \left(\frac{s}{\lambda}\right)^2 = \left(1 + \frac{s}{\lambda}\right)^2$$

$$1 + \frac{s}{\lambda} = \sqrt{1 + \left(\frac{L}{\lambda}\right)^2}$$

$$\left(\frac{s}{\lambda}\right) = -1 + \sqrt{1 + \left(\frac{L}{\lambda}\right)^2}$$

This is the condition for circular polarization

The pitch angle is given by

$$\tan \alpha = \frac{s}{\pi D} \quad \text{but } s = \frac{(\pi D)^2}{2\lambda}$$

$$\tan \alpha = \frac{(\pi D)^2}{2\lambda \pi D} = \frac{\pi D}{2\lambda}$$

Axial Mode:

If the dimensions of the helix are such that the circumference of one turn is approximately λ , the antenna radiates in the axial mode.

Advantages:

- Large Bandwidth and Good Efficiency
- The Radiation is circularly polarized and has a max value in the direction of helix axis.
- The directivity increase linearly with the length of the helix. It also referred as “helix beam antenna”.
- It acts like end fire array. The far field pattern of the helix can be developed by assuming that the helix consists of an array of N identical turns with an uniform spacing ‘s’ between them.

The 3db bandwidth is given by $f_{3db} = \frac{52}{C} \sqrt{\frac{\lambda^3}{NS}}$ deg

Directivity is given by $D_{\max} = \frac{15NSC^2}{\lambda^3}$

N= Number of turns

C= Circumference

S=Spacing between turns

λ =Wavelength

Applications:

Used in space telemetry application at the ground end of the telemetry link for satellite and space probes at HF and VHF.

Low Frequency, Medium Frequency and High Frequency Antennas:

The choice of an antenna for a particular frequency depends on following factors.

- Radiation Efficiency to ensure proper utilization of power.
- Antenna gain and Radiation Pattern
- Knowledge of antenna impedance for efficient matching of the feeder.
- Frequency characteristics and Bandwidth
- Structural consideration

5.3 Yagi-Uda array

Yagi-Uda or Yagi is named after the inventors Prof. S.Uda and Prof. H.Yagi around 1928. The basic element used in a Yagi is $\lambda/2$ dipole placed horizontally known as driven element or active element. In order to convert bidirectional dipole into unidirectional system, the passive elements are used which include reflector and director. The passive or parasitic elements are placed parallel to driven element, collinearly placed close together as shown in Fig 5.4. The Parasitic element placed in front of driven element is called director whose length is 5% less than the drive element. The element placed at the back of driven element is called reflector whose length is 5% more than that of driver element. The space between the element ranges between 0.1λ to 0.3λ .

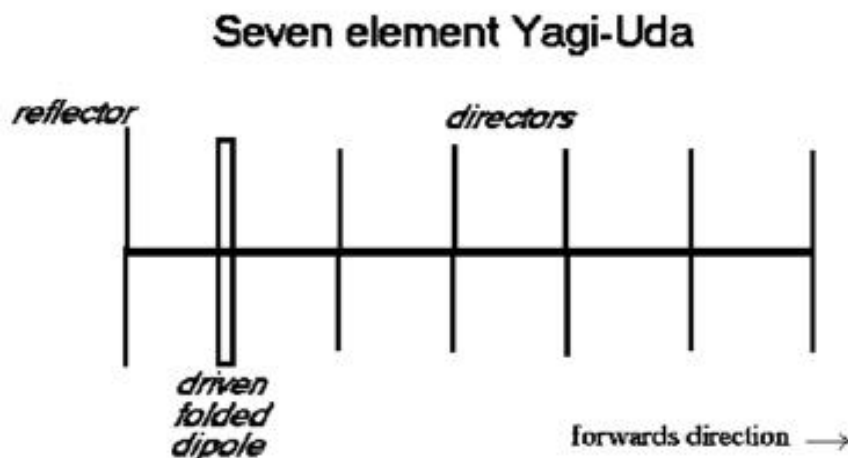

Fig 5.4 Yagi-Uda Antenna

For a three element system,

Reflector length = $500/f$ (MHz) feet

Driven element length = $475/f$ (MHz) feet

Director length = $455/f$ (MHz) feet.

The above relations are given for elements with length to diameter ratio between 200 to 400 and spacing between 0.1λ to 0.2λ . With parasitic elements the impedance reduces less than 73Ω and may be even less than 25Ω . A folded $\lambda/2$ dipole is used to increase the impedance. System may be constructed with more than one director. Addition of each director increases the gain by nearly 3 dB. Number of elements in a Yagi is limited to 11.

Basic Operation:

The phases of the current in the parasitic element depends upon the length and the distance between the elements. Parasitic antenna in the vicinity of radiating antenna is used either to reflect or to direct the radiated energy so that a compact directional system is obtained. A parasitic element of length greater than $\lambda/2$ is inductive which lags and of length less than $\lambda/2$ is capacitive which leads the current due to induced voltage. Properly spaced elements of length less than $\lambda/2$ act as director and add the fields of driven element. Each director will excite the next. The reflector adds the fields of driven element in the direction from reflector towards the driven element.

The greater the distance between driven and director elements, the greater the capacitive reactance needed to provide correct phasing of parasitic elements. Hence the length of element is tapered-off to achieve reactance.

A Yagi system has the following characteristics.

1. The three element array (reflector, active and director) is generally referred as “beam antenna”
2. It has unidirectional beam of moderate directivity with light weight, low cost and simplicity in design.
3. The band width increases between 2% when the space between elements ranges between 0.1λ to 0.15λ .
4. It provides a gain of 8 dB and a front-to-back ratio of 20dB.
5. Yagi is also known as super-directive or super gain antenna since the system results a high gain.
6. If greater directivity is to be obtained, more directors are used. Array up to 40 elements can be used.
7. Arrays can be stacked to increase the directivity.
8. Yagi is essentially a fixed frequency device. Frequency sensitivity and bandwidth of about

3% is achievable.

9. To increase the directivity Yagi's can be stacked one above the other or one by side of the other.

5.4 Corner reflector:

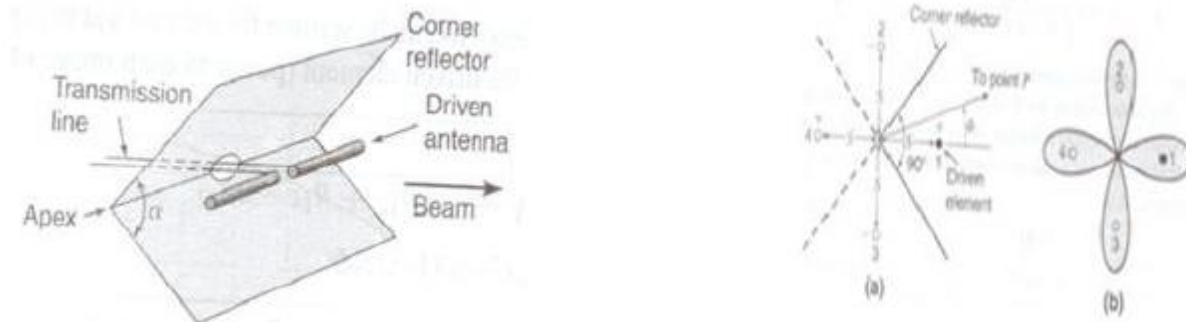

Fig. 5.5 Corner Reflector

Two flat reflecting sheets intersecting at an angle or corner as in Figure 5.5 form an effective directional antenna. When the corner angle $\alpha=90^\circ$, the sheets intersect at right angles, forming a square- corner reflector. Corner angles both greater or less than 90° can be used although there are practical disadvantages to angles much less than 90° . A corner reflector with $\alpha=180^\circ$ is equivalent to a flat sheet reflector and may be considered as limiting case of the corner reflector. Assuming perfectly conducting reflecting sheets infinite extent, the method of images can be applied to analyze the corner reflector antenna for angle $\alpha = 180^\circ/n$, where n is any positive integer. In the analysis of the 90° corner reflector there are 3 image elements, 2, 3 and 4, located shown in Figure. The driven antenna 1 the 3 images have currents of equal magnitude. The phase of the currents in 1 and 4 is same. The phase of the currents in 2 and 3 is the same but 180° out of phase with respect the currents in 1 and 4. All elements are assumed to be $\lambda/2$ long.

At the point P at a large distance D from the antenna. The field intensity is

$$E(\phi) = 2kI_1 \left[\cos(S_r \cos \phi) - \cos(S_r \sin \phi) \right]$$

Where

I_1 = current in each element

S_r = spacing of each element from the corner, $\text{rad} = 2\pi S/\lambda$

K = constant involving the distance D,

For arbitrary corner angles, analysis involves integrations of cylindrical functions. The emf V_t at the terminals at the center of the driven element is

$$V_1 = I_1 Z_{11} + I_1 R_{1L} + I_1 Z_{14} - 2I_1 Z_{12}$$

Where

Z_{11} = Self-Impedance of driven element R_{1L} = Equivalent loss resistance of driven element

Z_{12} = Mutual impedance of element 1 and 2

Z_{14} = Mutual impedance of element 1 and 4

If 'P' is the power delivered to the driven element, then from symmetry.

$$I_1 = \sqrt{\frac{P}{R_{11} + R_{1L} + R_{14} - 2R_{12}}}$$

$$E(\phi) = 2k \sqrt{\frac{P}{R_{11} + R_{1L} + R_{14} - 2R_{12}}} \left[\cos(S_r \cos \phi) - \cos(S_r \sin \phi) \right]$$

The Field Intensity at 'P' with reflector removed

$$E_{HW}(\phi) = 2k \sqrt{\frac{P}{R_{11} + R_{1L}}}$$

The Gain in the field intensity of a square corner reflector antenna over a single $\lambda/2$ antenna

$$G_f(\phi) = \frac{E(\phi)}{E_{HW}(\phi)}$$

$$G_f(\phi) = 2 \sqrt{\frac{R_{11} + R_{1L}}{R_{11} + R_{1L} + R_{14} - 2R_{12}}} \left[\cos(S_r \cos \phi) - \cos(S_r \sin \phi) \right]$$

Where the expression in brackets is the pattern factor and the expression included under the radical sign is the coupling factor. The pattern shape is a function of both the angle, and the antenna-to-corner spacing S. For the 60° corner the analysis requires a total of 6 elements, 1 actual antenna and 5 images as in Figure.

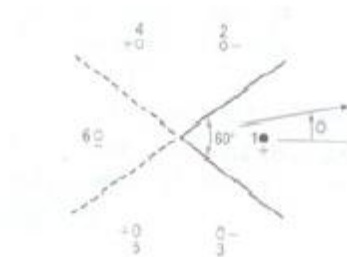

5.5 Parabolic reflectors

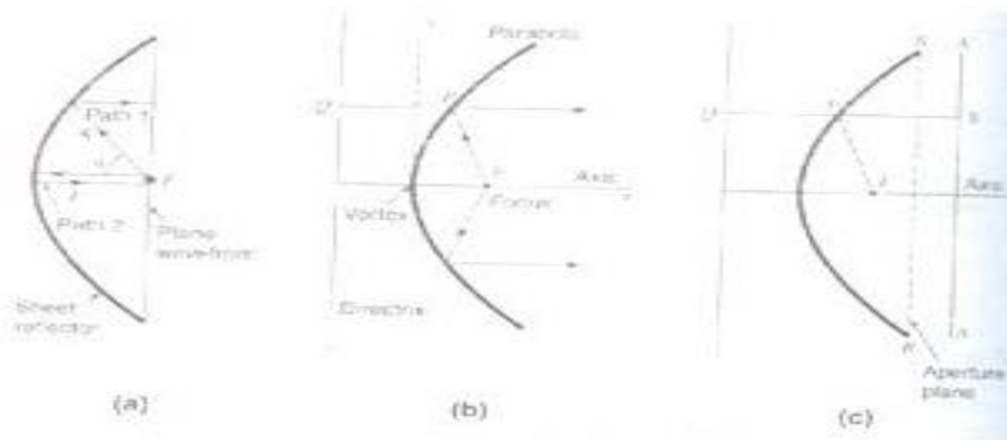

Fig 5.6 Parabolic Reflector

Suppose that we have a point source and that we wish to produce a plane-wave front over a large aperture by means of a sheet reflector. Referring to Fig(a), it is then required that the distance from the source to the plane-wave front via path 1 and 2 be equal or The parabola-general properties

$$2L = R(1 + \cos \theta)$$

$$R = \frac{2L}{1 + \cos \theta}$$

Referring to Fig. (b), the parabolic curve may be defined as follows. The distance from any point P on a parabolic curve to a fixed point F, called the focus, is equal to the perpendicular distance to a fixed line called the directrix. Thus, in Fig.(b), $PF = PQ$. Referring now to Fig.(c), let AA' be a line normal to the axis at an arbitrary distance QS from the directrix. Since $PS = QS - PQ$ and $PF = PQ$, it follows that the distance from the focus to S is

$$PF + PS = PF + QS - PQ = QS$$

Thus, a property of a parabolic reflector is that waves from an isotropic source at the focus that are reflected from the parabola arrive at a line AA' with equal phase. The “image” of the focus is the directrix and the reflected field along the line AA' appears as though it originated at the directrix as a plane wave. The plane BB' (Fig. 5.6c) at which a reflector is cut off is called the aperture plane.

A cylindrical parabola converts a cylindrical wave radiated by an in-phase line source at the focus, as in Fig. 5.7a, into a plane wave at the aperture, or a paraboloid-of-revolution converts a spherical wave from an isotropic source at the focus, as in Fig. 5.7b, into a uniform plane wave at the aperture. Confining our attention to a single ray or wave path, the paraboloid has the property of directing or collimating radiation from the focus into a beam parallel to the axis. The presence of

the primary antenna in the path of the reflected wave, as in the above examples, has two principle disadvantages. These are, first, that waves reflected from the parabola back to the primary antenna produce interaction and mismatching. Second, the primary antenna acts as an obstruction, blocking out the central portion of the aperture and increasing the minor lobes. To avoid both effects, a portion of the paraboloid can be used and the primary antenna displaced as in Fig below This is called an offset feed.

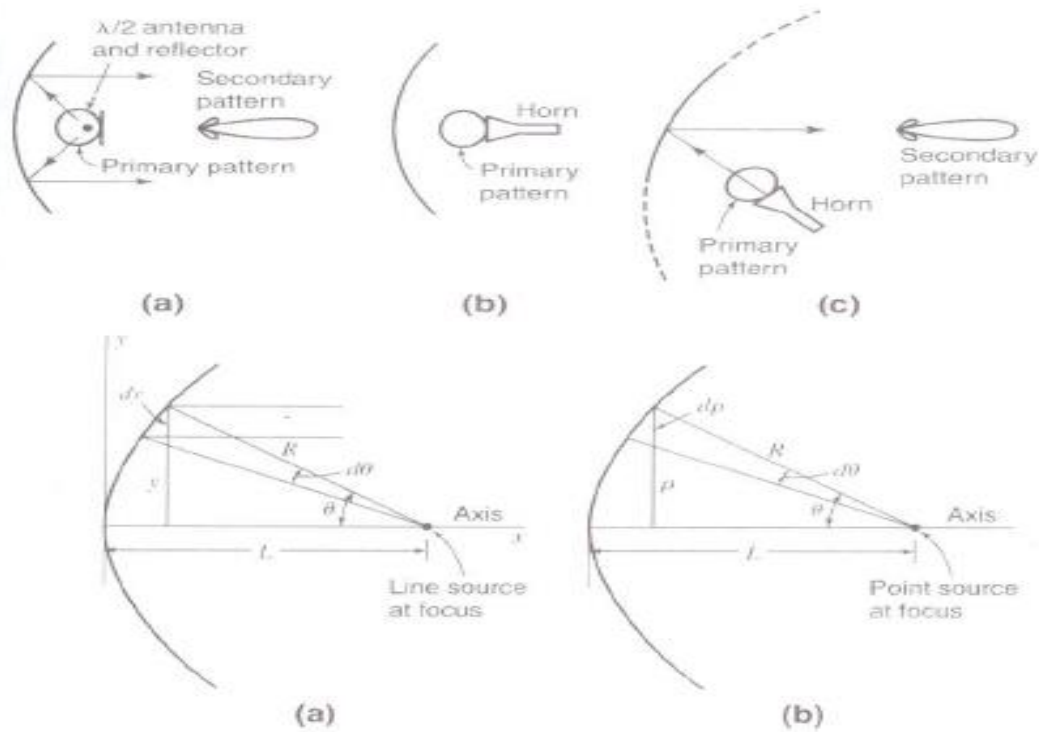

Fig .5.7 parabolic feed structure

Let us next develop an expression for the field distribution across the aperture of a parabolic reflector. Since the development is simpler for a cylindrical parabola, this case is treated first, as an introduction to the case for a paraboloid. Consider a cylindrical parabolic reflector with line source as in Fig.a. The line source is isotropic in a plane perpendicular to its axis (plane of page). For a unit distance in the z direction the power P in a strip of width dy is

$$P = dyS_y$$

Where S_y = the power density at y, $W m^{-2}$

$$P = U'd\theta$$

U' =the power per unit angle per unit length in the direction

$$S_y dy = U'd\theta$$

$$\frac{S_y}{U'} = \frac{1}{(d/d\theta)(R \sin \theta)}$$

$$R = \frac{2L}{1 + \cos \theta}$$

$$S_y = \frac{1 + \cos \theta}{2L} U'$$

The ratio of power density

$$\frac{S_\theta}{S_0} = \frac{1 + \cos \theta}{2}$$

The field intensity ratio in the aperture plane is equal to the square root of the power ratio

$$\frac{E_\theta}{E_0} = \sqrt{\frac{1 + \cos \theta}{2}}$$

$$P = 2\pi \rho d\rho S\rho$$

$$P = 2\pi \sin \theta d\theta U$$

Equating the above two equations, we get,

$$\rho d\rho S\rho = \sin \theta d\theta U$$

$$\frac{S_\rho}{U} = \frac{\sin \theta}{\rho(d\rho/d\theta)}$$

$$S_\rho = \frac{(1 + \cos \theta)^2}{4L^2} U$$

$$\frac{S_\theta}{S_0} = \frac{(1 + \cos \theta)^2}{4}$$

$$\frac{E_\theta}{E_0} = \frac{1 + \cos \theta}{2}$$

5.6 LOG PERIODIC DIPOLE ARRAY

The log periodic dipole array (LPDA) is one antenna that almost everyone over 40 years old has seen. They were used for years as TV antennas. The chief advantage of an LPDA is that it is frequency-independent. Its input impedance and gain remain more or less constant over its operating bandwidth, which can be very large. Practical designs can have a bandwidth of an octave or more. Although an LPDA contains a large number of dipole elements, only 2 or 3 are active at any given frequency in the operating range. The electromagnetic fields produced by these active elements add up to produce a unidirectional radiation pattern, in which maximum radiation is off the small end of the array. The radiation in the opposite direction is typically 15 - 20 dB below the

maximum. The ratio of maximum forward to minimum rearward radiation is called the Front-to-Back (FB) ratio and is normally measured in dB.

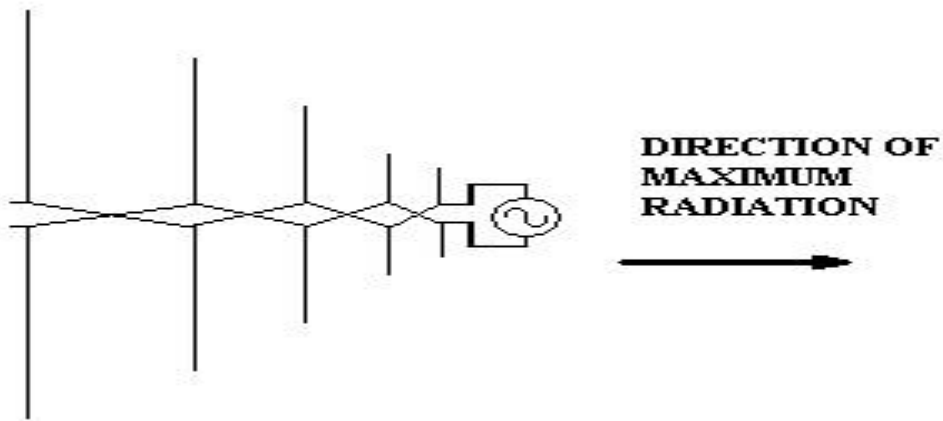

Fig .5.8 Log periodic Dipole Array

The log periodic antenna is characterized by three interrelated parameters, α , σ and τ as well as the minimum and maximum operating frequencies, f_{MIN} and f_{MAX} . The diagram below shows the relationship between these parameters.

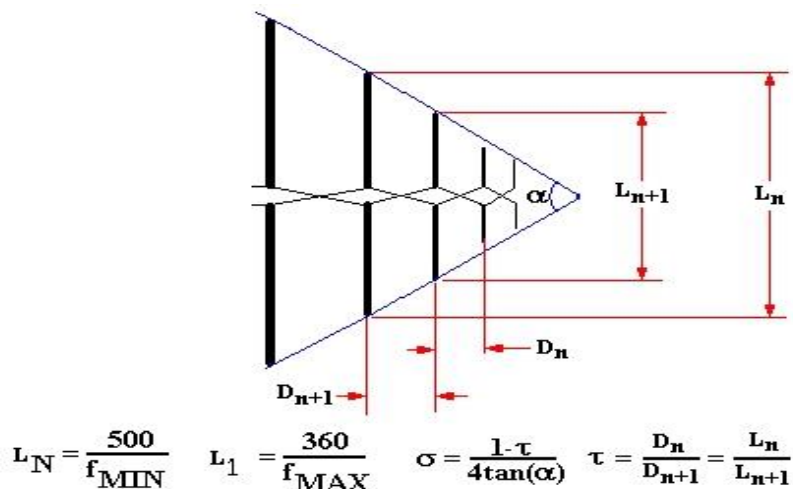

Fig .5.9 Relationship between different parameters

Unlike many antenna arrays, the design equations for the LPDA are relatively simple to work with. If you would like to experiment with LPDA designs, click on the link below. It will open an EXCEL spreadsheet that does LPDA design.

5.7 LENS ANTENNAS

With a LENS ANTENNA you can convert spherically radiated microwave energy into a plane wave (in a given direction) by using a point source (open end of the waveguide) with a COLLIMATING LENS. A collimating lens forces all radial segments of the spherical wavefront into parallel paths. The point source can be regarded as a gun which shoots the microwave energy toward the lens. The point source is often a horn radiator or a simple dipole antenna.

Waveguide type: the waveguide-type lens is sometimes referred to as a conducting- type. It consists of several parallel concave metallic strips which are placed parallel to the electric field of the radiated energy fed to the lens, as shown in Figure 3-10A and 3-10B. These strips act as waveguides in parallel for the incident (radiated) wave. The strips are placed slightly more than a half wavelength apart.

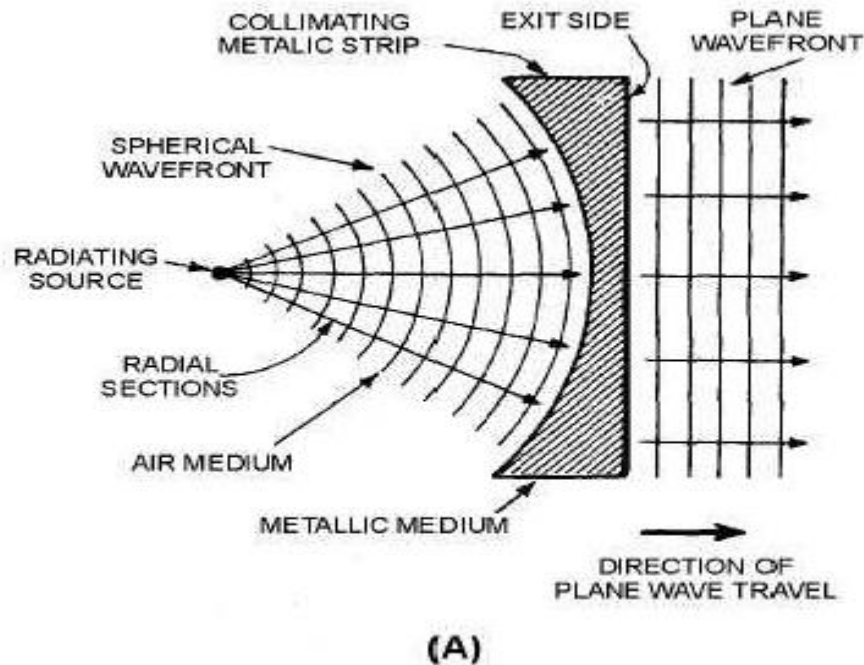

Fig 5.10 Lens Antenna

Advantages of Lens Antenna

- Can be used as wideband antenna since its shape is independent of frequency.
- Provides good collimation.
- Internal dissipation losses are low, with dielectric materials having low loss tangent.
- Easily accommodate large band width required by high data rate systems
- Quite in-expensive and have good fabrication tolerance

Disadvantages of Lens Antenna

- Bulky and Heavy
- Complicated Design
- Refraction at the boundaries of the lens

5.8 Antennas for Special applications

5.8.1 Sleeve antenna

Ground plane or sleeve type $\lambda/4$ long cylindrical system is called a sleeve antenna. The radiation is in a plane normal to the axis of this antenna. The second variety of sleeve is similar to stub with ground plane having the feed point at the centre of the stub. The lower end of the stub is a cylindrical sleeve of length $\lambda/8$.

A balanced-sleeve dipole antenna corresponding to the sleeve stub is shown in Fig. This is fed with a coaxial cable and balance to unbalance transformer or balun. For L ranging between $\lambda/2$ to λ , the operating frequency ranges through 2 to 1.

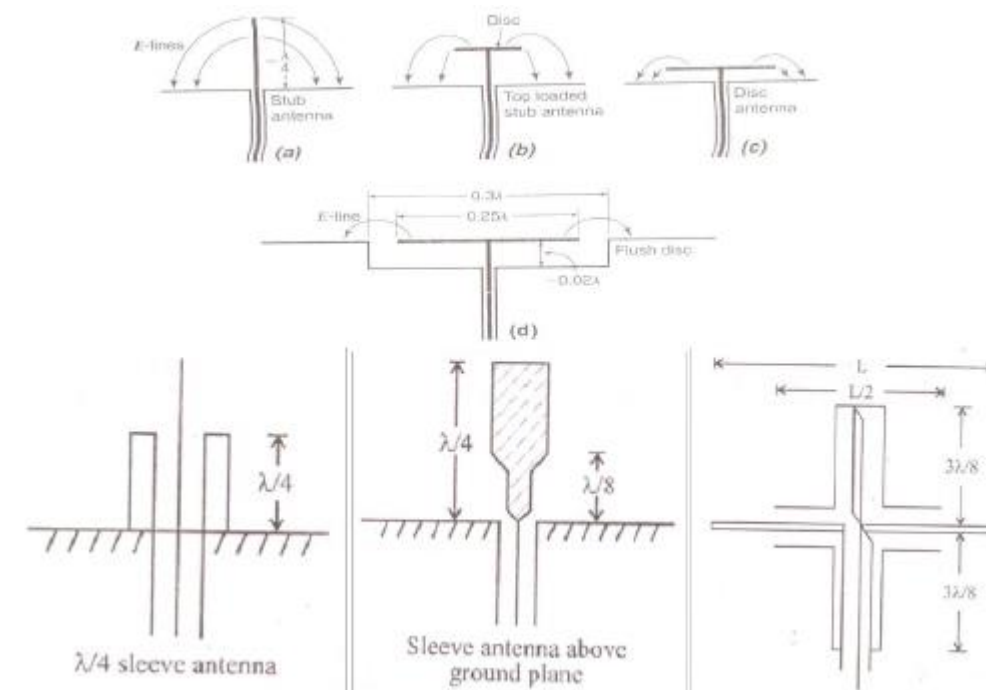

Fig 5.11 Sleeve Antenna

Evolution of flush-disk antenna from vertical $\lambda/4$ stub antenna

It is the modified ground plane antenna.

Here the ground plane has de-generated into a sleeve or cylinder $\lambda/4$ long.

Maximum radiation is normal to the axis.

5.8.2 Turn Stile Antenna

The Antenna is similar to stub antenna with ground plane but with a feed point moved to approximately the center of the stub. A basic turn stile consists of two horizontal short dipoles placed normal to each other as shown in Fig. The individual field patterns are 'Figure of eight' fitted by 90°. The total field pattern is given by

$$E = \sin \theta \cos \omega t + \cos \theta \sin \omega t$$

$$E = \sin(\theta + \omega t)$$

$$\omega t = -\theta$$

$$|E| = \sqrt{\cos^2 \omega t + \sin^2 \omega t} = 1$$

$$E = \frac{\cos(90^\circ \cos \theta)}{\sin \theta} \cos \omega t + \frac{\cos(90^\circ \sin \theta)}{\cos \theta} \sin \omega t$$

$$I_1 = \frac{V}{70 + j70}$$

$$I_2 = \frac{V}{70 - j70}$$

Where

V = Impressed emf

I1 = current at terminals of dipole 1

I2 = current at terminals of dipole 2

Thus

$$I_1 = \frac{V}{99} \angle -45^\circ$$

$$I_2 = \frac{V}{99} \angle +45^\circ$$

$$Z = \frac{1}{Y} = \frac{1}{\left[\frac{1}{70 + j70} \right] + \left[\frac{1}{70 - j70} \right]} = 70 + j0 (\Omega)$$

The Antenna is similar to stub antenna with ground plane but with a feed point moved to approximately the center of the stub

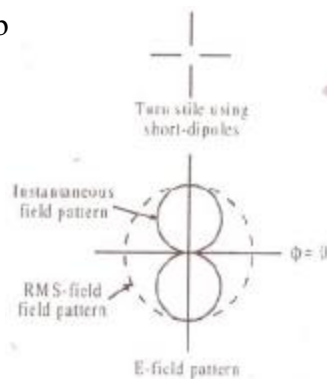

Turn stile array with individual field pattern

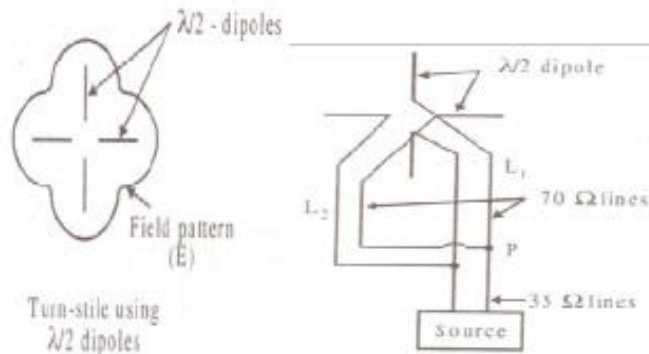

Fig.5.12. Turn stile array with resultant field pattern

The turn stile is most suited for TV transmission for frequency from 50 MHz. Directivity can be increased by stacking super turn stiles one above the other as shown in Figure.

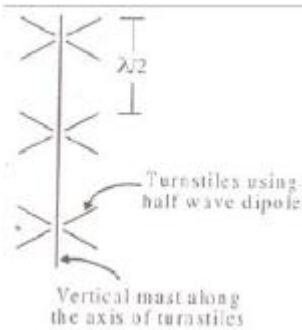

Fig 5.13 Stack of turn stile array

5.8.3 Omni-directional antennas

Slotted cylinder, and turnstile are almost omni-directional in horizontal plane. Clover-leaf is one more type of omni-directional whose directivity is much higher than that of turnstile. The system basically contains horizontal dipole which is bidirectional in vertical plane. A circular loop antenna as shown in Fig can be used to obtain omnidirectional radiation pattern.

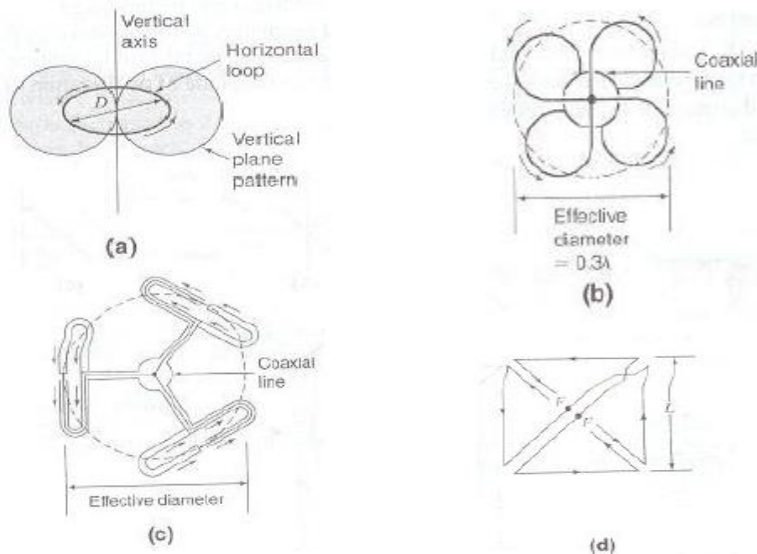

Fig.5.14 a) Circular Loop Antenna b) Approximately equivalent arrangements of “clover-leaf” type c) “triangular-loop” type Antenna d) Square or Alford loop

5.8.4 Antenna for Mobile Application

Switched Beam Antenna:

The base station antenna has several selectable beams of which each covers a part of the cell area as shown in the Figure 5.24. The switched beam antenna is constructed based on Butler matrix, which provides one beam per antenna element. The system operation is very simple but has limited adaptability.

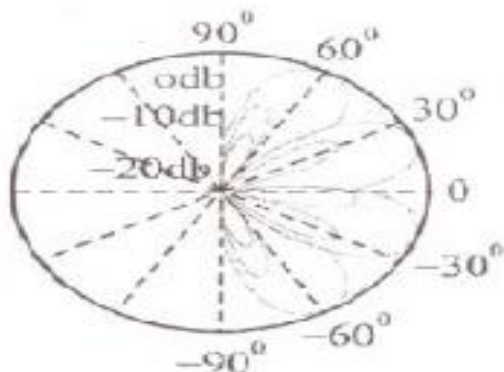

Fig 5.15 Switched Beam Pattern

Adaptive Antenna: Adaptive array is the most comprehensive and complex configuration. The system consists of several antennas where each antenna is connected to separate trans-receiver and Digital Signal Processor as shown in Fig. DSP controls the signal level to each element depending upon the requirements. Butler matrix can be adapted for the improvement of SNR during reception. Direction of arrival finding and optimization algorithms are used to select the complex weights for each mobile users. For frequency domain duplexing the transmission weights are estimated based on Direction of arrival information.

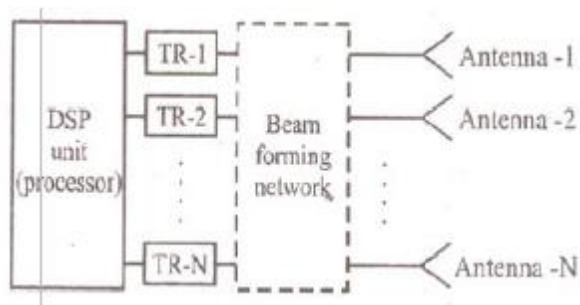

Fig 5.16. Adaptive Antenna

Antenna for satellite:

- High Frequency Transmitting Antenna
- Parabolic Reflector

6.8.5 Antennas for Ground Penetrating Radar (GPR)

- Like Earth Surface Radars, the radars can be used to detect underground anomalies both natural and Human Made.
- The anomalies include buried metallic or nonmetallic objects, earth abnormalities etc.,
- Pulse and its echo pulse are used for processing.
- Far field radar equation to be modified as distance travelled by wave is less.
- Power required is more since ground is lossy medium.
- Mismatch at air-ground interface.
- Pulse width should be less.

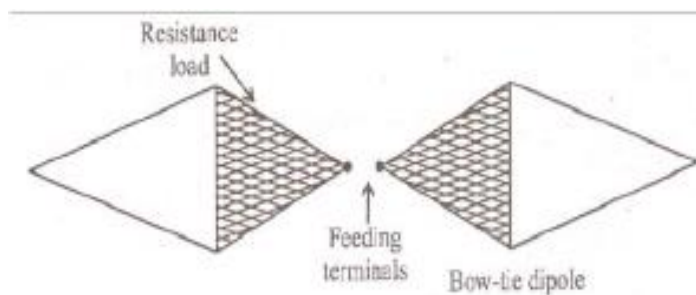

Fig 5.17 Ground Penetrating Radar (GPR) Antenna

5.8.6 Embedded Antennas

- If dipole is embedded in a dielectric medium of relative permittivity $\epsilon_r (>1)$, then its length can be reduced.
- A $\lambda/2$ dipole resonates at the same frequency when embedded in a dielectric medium having a length $0.5\lambda/\text{sq root of } \epsilon_r$
- If $\epsilon_r = 4$, length required is half.
- Used in Bluetooth technology, interfacing RF Networks.

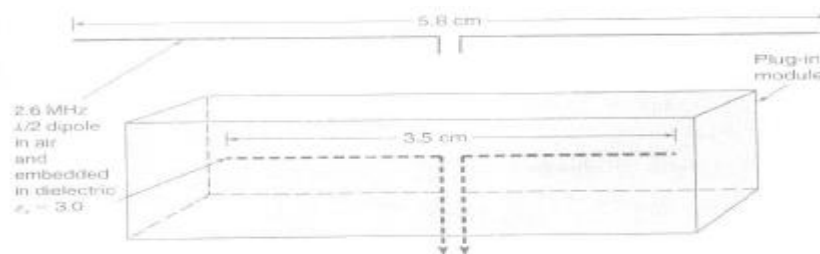

Fig 5.18..Half-wavelength dipole embedded in a dielectric for Bluetooth Application

5.8.7 Ultra Wide Band Antenna

- Used for digital Applications
- Pulse Transmission which results in Large bandwidth.
- Phase dispersion of pulse (transmitted at different instant of time)
- Degrading of signals

V Antenna used for Communication

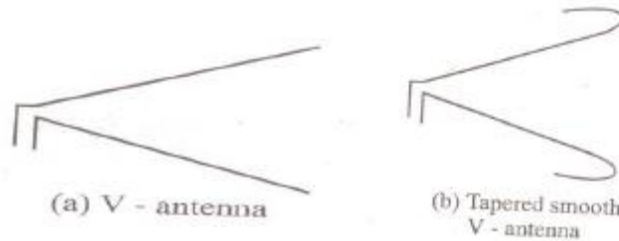

Fig.5.19 Ultra Wide Band Antenna

5.8.8 Plasma antenna

- A plasma surface wave can be excited along a column of low-pressure gas by adequate RF power coupled to the column in a glass tube.
- It is a system in which the radar cross section is only the thin wall glass tube when not transmitting. With a laser beam producing the plasma the radar cross section becomes zero when laser is off.

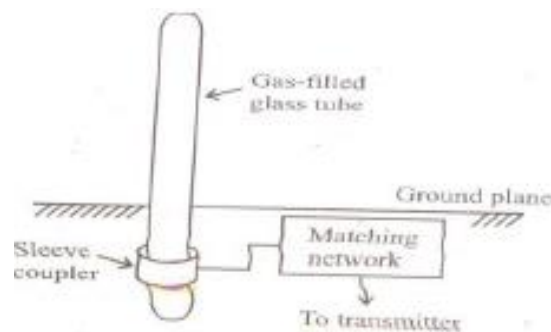

Fig.5.20 Plasma antenna

5.9 OUTCOMES

- To solve problems related to different types of antennas.
- Concept of Different antenna types is understood

5.10 Questions

1. With a neat figure explain the working of Yagi-Uda antenna. Write the design formulae for different components used in Yagi-Uda antenna. Also mention the applications of Yagi-Uda antenna.
2. Write a short note on log-periodic antenna.
3. Explain the features of a helical antenna. Explain the practical design considerations of helical antenna.
4. With a neat sketch explain the principle of lens antenna. Also list the merits and demerits of lens antenna.
5. Explain the corner reflector antenna.
6. What are parabolic reflectors? Where are these antennas used?
7. Write short notes on the following:
 - i. Ultra-wide band antenna (4m)
 - ii. Turnstile antenna (4m)
 - iii. Patch antenna (4m)
 - iv. Antenna for ground penetrating radar (4m)
 - v. Plasma antenna (4m)
8. Draw the construction details of an embedded antenna.

5.11 Further Readings

1. **Antenna Theory Analysis and Design** - C A Balanis, 3rd Edn, John Wiley India Pvt. Ltd, 2008
2. **Antennas and Propagation for Wireless Communication Systems** - Sineon R Saunders, John Wiley, 2003