



MODULE 5: MULTIMEDIA NETWORKING

- 5.1 Multimedia Networking Applications
 - 5.1.1 Properties of Video
 - 5.1.2 Properties of Audio
 - 5.1.2.1 PCM Encoder
 - 5.1.2.2 PCM Decoder
 - 5.1.3 Types of Multimedia Network Applications
 - 5.1.3.1 Streaming Stored Audio & Video
 - 5.1.3.2 Conversational Voice- and Video-over-IP
 - 5.1.3.3 Streaming Live Audio & Video
- 5.2 Streaming Stored Video
 - 5.2.1 UDP Streaming
 - 5.2.2 HTTP Streaming
 - 5.2.2.1 Client Application Buffer & TCP Buffers
 - 5.2.2.2 Early Termination & Repositioning the Video
 - 5.2.3 Adaptive Streaming & DASH
 - 5.2.3.1 DASH
 - 5.2.4 CDN
 - 5.2.4.1 Motivation for CDN
 - 5.2.4.2 CDN Types
 - 5.2.4.3 CDN Operation
 - 5.2.4.4 Cluster Selection Strategies
- 5.3 Voice-over-IP
 - 5.3.1 Limitations of the Best Effort IP Service
 - 5.3.1.1 Packet Loss
 - 5.3.1.2 End-to-End Delay
 - 5.3.1.3 Packet Jitter
 - 5.3.2 Removing Jitter at the Receiver for Audio
 - 5.3.3 Recovering from Packet Loss
 - 5.3.3.1 FEC
 - 5.3.3.2 Interleaving
 - 5.3.3.3 Error Concealment
- 5.4 Protocols for Real-Time Conversational Applications
 - 5.4.1 RTP
 - 5.4.1.1 RTP Basics
 - 5.4.1.2 RTP Packet Header Fields
 - 5.4.2 SIP
 - 5.4.2.1 Setting up a Call to a Known IP Address
 - 5.4.2.2 SIP Messages
 - 5.4.2.3 Name Translation & User Location
- 5.5 Network Support for Multimedia
 - 5.5.1 Dimensioning Best-Effort Networks
 - 5.5.2 Providing Multiple Classes of Service
 - 5.5.2.1 Motivating Scenarios
 - 5.5.2.1.1 Approaches for Providing Isolation among Traffic Classes
 - 5.5.2.1.1.1 Using Traffic Policing
 - 5.5.2.1.1.2 Using Packet Scheduling
 - 5.5.2.2 Scheduling Mechanisms
 - 5.5.2.2.1 FIFO
 - 5.5.2.2.2 Priority Queuing
 - 5.5.2.2.3 RRQ
 - 5.5.2.2.4 WFQ



COMPUTER NETWORKS

5.5.2.3 Policing: The Leaky Bucket

5.5.2.3.1 Leaky Bucket Operation

5.5.3 DiffServ

5.5.4 Per-Connection QoS Guarantees: Resource Reservation & Call Admission

5.5.4.1 Mechanisms for Guaranteed QoS

VTUNOTESBYSRI



MODULE 5: MULTIMEDIA NETWORKING

5.1 Multimedia Networking Applications

- A multimedia network application can be defined as any application that employs audio or video.

5.1.1 Properties of Video

1) High Bit Rate

- Video distributed over the Internet use
 - 100 kbps for low-quality video conferencing.
 - 3 Mbps for streaming high-definition (HD) movies.
- The higher the bit-rate,
 - better the image quality and
 - better the overall user viewing experience.

2) Video Compression

- A video can be compressed, thereby trading off video-quality with bit-rate.
- A video is a sequence of images, displayed at a constant rate.
For example: 24 or 30 images per second.
- An uncompressed digital image consists of an array of pixels.
- Each pixel is encoded into a number of bits to represent luminance and color.
- There are two types of redundancy in video:
 - 1) Spatial Redundancy**
 - An image that consists of mostly white space has a high degree of redundancy.
 - These images can be efficiently compressed without sacrificing image quality.
 - 2) Temporal Redundancy**
 - Temporal redundancy reflects repetition from image to subsequent image.
 - For example:
 - If image & subsequent image are same, re-encoding of subsequent image can be avoided.



COMPUTER NETWORKS

5.1.2 Properties of Audio

- PCM (Pulse Code Modulation) is a technique used to change an analog signal to digital data (digitization).
- PCM consists of 1) Encoder at the sender and 2) Decoder at the receiver.

5.1.2.1 PCM Encoder

- Digital audio has lower bandwidth requirements than video.
- Consider how analog audio is converted to a digital-signal:
- The analog audio-signal is sampled at some fixed rate. This operation is referred to as sampling.
- For example: 8000 samples per second.
- The value of each sample is an arbitrary real number.
- Each sample is then rounded to one of a finite number of values. This process is called quantization.
- The number of such finite values is called as quantization-values.
- The number of quantization-values is typically a power of 2. For ex: $256(2^8)$ quantization-values.
- Each of the quantization-values is represented by a fixed number of bits.
- For example:
 - If there are $256(2^8)$ quantization-values, then each value is represented by 8 bits.
- Bit representations of all values are then concatenated to form digital representation of the signal. This process is called encoding.
- For example:
 - If an analog-signal is sampled at 8000 samples per second & each sample is represented by 8 bits, then the digital-signal will have a rate of 64000 bits per second ($8000*8=64000$).

5.1.2.2 PCM Decoder

- For playback through audio speakers, the digital-signal can be converted back to an analog-signal. This process is called decoding.
- However, the decoded analog-signal is only an approximation of the original signal.
- The sound quality may be noticeably degraded.
- The decoded signal can better approximate the original analog-signal by increasing
 - i) sampling rate and
 - ii) number of quantization-values,
- Thus, there is a trade-off between
 - quality of the decoded signal and
 - bit-rate & storage requirements of the digital-signal.



COMPUTER NETWORKS

5.1.3 Types of Multimedia Network Applications

- Three broad categories of multimedia applications:
 - 1) Streaming stored audio/video
 - 2) Conversational voice/video-over-IP and
 - 3) Streaming live audio/video.

5.1.3.1 Streaming Stored Audio & Video

- The underlying medium is prerecorded video. For example: a movie.
- These prerecorded videos are placed on servers.
- The users send requests to the servers to view the videos on-demand.
- Nowadays, many Internet companies provide streaming video. For example: YouTube.
- Three key distinguishing features of streaming stored video:

1) Streaming

- The client begins video playout within few seconds after it begins receiving the video from the server.
- At the same time,
 - i) The client will be playing out from one location in the video.
 - ii) The client will be receiving later parts of the video from the server.
- This technique avoids having to download the entire video-file before playout begins.

2) Interactivity

- The media is prerecorded, so the user may pause, reposition or fast-forward through video-content.
- The response time should be less than a few seconds.

3) Continuous Playout

- Once playout of the video begins, it should proceed according to the original timing of the recording.
- The data must be received from the server in time for its playout at the client.
Otherwise, users experience video-frame skipping (or freezing).

5.1.3.2 Conversational Voice- and Video-over-IP

- Real-time conversational voice over the Internet is often referred to as Internet telephony.
- It is also commonly called Voice-over-IP (VoIP).
- Conversational video includes the video of the participants as well as their voices.
- Most of today's voice applications allow users to create conferences with three or more participants.
- Nowadays, many Internet companies provide voice application. For example: Skype & Google Talk.
- Two parameters are particularly important for voice applications:
 - 1) Timing considerations and
 - 2) Tolerance of data loss
- Timing considerations are important because voice applications are highly delay-sensitive.
- Loss-tolerant means
Occasional loss only causes occasional glitches in audio playback & these losses can be partially/fully hidden.

5.1.3.3 Streaming Live Audio & Video

- These applications are similar to broadcast radio, except that transmission takes place over Internet.
- These applications allow a user to receive a live radio transmitted from any corner of the world.
- For example: live cricket commentary.
- Today, thousands of radio stations around the world are broadcasting content over the Internet.
- Live broadcast applications have many users who receive the same audio program at the same time.
- The network must provide an average throughput that is larger than the video consumption rate.



COMPUTER NETWORKS

5.2 Streaming Stored Video

- Prerecorded videos are placed on servers.
- Users send requests to these servers to view the videos on-demand.
- The media is prerecorded, so the user may pause, reposition or fast-forward through video-content.
- Three categories of applications:
 - 1) UDP streaming
 - 2) HTTP streaming and
 - 3) Adaptive HTTP streaming.
- A main characteristic of video-streaming is the extensive use of client-side buffering.
- Two advantages of client-side buffering:
 - 1) Client-side buffering can mitigate effects of varying end-to-end delays
 - 2) This can mitigate effects of varying amounts of available bandwidth b/w server & client.

5.2.1 UDP Streaming

- The server transmits video at a rate that matches the client's video consumption rate.
- The server transmits the video-chunks over UDP at a steady rate.
- UDP does not employ a congestion-control mechanism.
- Therefore, the server can push packets into the network at the video consumption rate.
- Typically, UDP streaming uses a small client-side buffer. (RTP → Real-Time Transport Protocol).
- Using RTP, the server encapsulates the video-chunks within transport packets.
- The client & server also maintain a control-connection over which the client sends commands (such as pause, resume and reposition).
- The RTSP (Real-Time Streaming Protocol) is a popular open protocol for a control-connection.
- Disadvantages:
 - 1) Unreliability**
 - UDP streaming can fail to provide continuous playout of varying amt of available bandwidth
 - 2) Costly & Complex**
 - A media control server (RTSP) is required
 - to process client-to-server interactivity requests and
 - to track client-state for each ongoing client-session.
 - This increases the overall cost and complexity of deploying a large-scale application.
 - 3) Firewall Problem**
 - Many firewalls are configured to block UDP traffic.
 - This prevents the users behind the firewalls from receiving the video.



COMPUTER NETWORKS

5.2.2 HTTP Streaming

- The video is stored in an HTTP server as an ordinary file with a specific URL.
- Here is how it works:
 - 1) When a user wants to see the video, the client
 - establishes a TCP connection with the server and
 - issues an HTTP GET request for that URL.
 - 2) Then, the server responds with the video file, within an HTTP response message.
 - 3) On client side, the bytes are collected in a client application buffer.
 - 4) Once no. of bytes in this buffer exceeds a specific threshold, the client begins playback.
- Advantages:
 - 1) Not Costly & Complex**
 - Streaming over HTTP avoids the need for a media control server (RTSP).
 - This reduces the cost of deploying a large-scale application.
 - 2) No Firewall Problem**
 - The use of HTTP over TCP also allows the video to traverse firewalls and NATs more easily.
 - 3) Prefetching Video**
 - The client downloads the video at a rate higher than the consumption rate.
 - Thus, prefetching video-frames that are to be consumed in the future.
 - This prefetched video is stored in the client application buffer
- Nowadays, most video-streaming applications use HTTP streaming. For example: YouTube

5.2.2.1 Client Application Buffer & TCP Buffers

- Figure 5.1 illustrates the interaction between client and server for HTTP streaming.
- On the server side,
 - 1) The bytes of the video file are sent into the server's socket.
 - 2) Then, the bytes are placed in the TCP send buffer before.
 - 3) Finally, the bytes are transmitted into the Internet.
- On the client side,
 - 1) The application (media-player) reads bytes from the TCP receive-buffer (thro client-socket)
 - 2) Then, the application places the bytes into the client-buffer.
 - 3) At the same time, the application periodically
 - grabs video-frames from the client-buffer
 - decompresses the frames and
 - displays the frames on the user's screen.

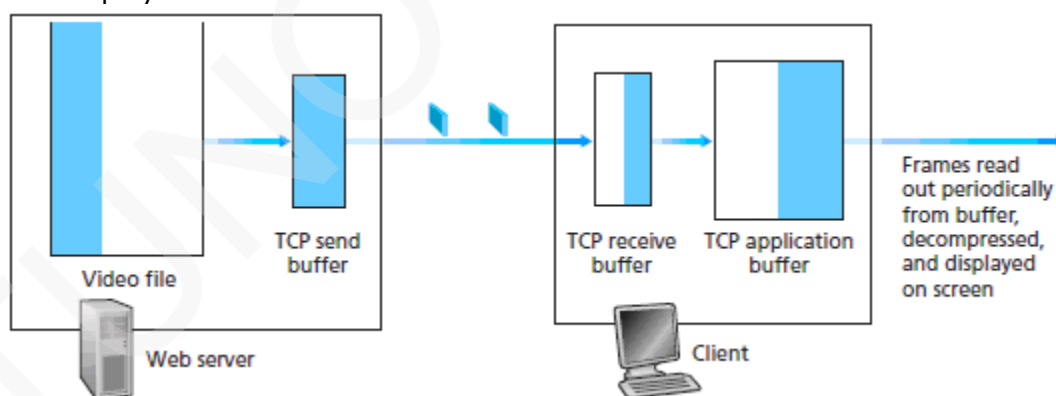

Figure 5.1: Streaming stored video over HTTP/TCP

5.2.2.2 Early Termination & Repositioning the Video

- HTTP streaming systems make use of the byte-range header in the HTTP GET request message.
- Byte-range header specifies the range of bytes the client currently wants to retrieve from the video.
- This is particularly useful when the user wants to reposition to a future point in the video.
- When the user repositions to a new position, the client sends a new HTTP request.
- When server receives new HTTP request, the server sends the requested-bytes.
- Disadvantage:
 - When a user repositions to a future point in the video, some prefetched-but-not-yet-viewed data will go unwatched. This results in a waste of bandwidth and server-resources.

“Too many of us are not living our dreams because we are living our fears.” —Les Brown



COMPUTER NETWORKS

5.2.3 Adaptive Streaming & DASH

- Problem with HTTP streaming:
All clients receive the same encoding of video, despite the large variations in the amount of bandwidth available to different clients.
Solution: Use DASH (Dynamic Adaptive Streaming over HTTP).

5.2.3.1 DASH

- The video is encoded into several different versions.
- Each version has a different bit-rate and a different quality level.
- Two main tasks:
 - 1) The client dynamically requests video-chunks from the different versions: low & high.
 - i) When the available bandwidth is high, the client selects chunks from a high-rate version.
For ex: Fiber connections can receive a high-quality version.
 - ii) When the available bandwidth is low, the client naturally selects from a low-rate version.
For ex: 3G connections can receive a low-quality version.
 - 2) The client adapts to the available bandwidth if end-to-end bandwidth changes during session.
 - This feature is particularly important for mobile-users.
 - The mobile-users see their bandwidth fluctuate as they move with respect to base-stations.
- HTTP server stores following files:
 - 1) Each video version with a different URL.
 - 2) Manifest file provides a URL for each version along with its bit-rate.
- Here is how it works:
 - 1) First, the client requests the manifest file and learns about the various versions.
 - 2) Then, the client selects one chunk at a time by specifying
 - URL and
 - byte range in an HTTP GET request message.
 - 3) While downloading chunks, the client
 - measures the received bandwidth and
 - runs a rate determination-algorithm.
 - i) If measured-bandwidth is high, client will choose chunk from high-rate version.
 - ii) If measured-bandwidth is low, client will choose chunk from low-rate version
 - 4) Therefore, DASH allows the client to freely switch among different quality-levels.
- Advantages:
 - 1) DASH can achieve continuous playout at the best possible quality level w/o frame freezing.
 - 2) Server-side scalability is improved: Because
 - the client maintains the intelligence to determine which chunk to send next.
 - 3) Client can use HTTP byte-range request to precisely control the amount of prefetched video.



COMPUTER NETWORKS

5.2.4 CDN

5.2.4.1 Motivation for CDN

- The streaming video service can be provided is as follows:
 - 1) Build a single massive data-center.
 - 2) Store all videos in the data-center and
 - 3) Stream the videos directly from the data-center to clients worldwide.
- Three major problems with the above approach:
 - 1) More Delay**
 - If links provides a throughput lesser than consumption-rate, the end-to-end throughput will also be below the consumption-rate.
 - This results in freezing delays for the user.
 - 2) Network Bandwidth is wasted**
 - A popular video may be sent many times over the same links.
 - 3) Single Point of Failure:**
 - If the data-center goes down, it cannot distribute any video streams.

Problem Solution: Use CDN (Content Distribution Network).

5.2.4.2 CDN Types

- A CDN
 - manages servers in multiple geographically distributed locations
 - stores copies of the videos in its servers, and
 - attempts to direct each user-request to a CDN that provides the best user experience.
- The CDN may be a private CDN or a third-party CDN.
 - 1) Private CDN**
 - A private CDN is owned by the content provider itself.
 - For example:
 - Google's CDN distributes YouTube videos
 - 2) Third Party CDN**
 - A third-party CDN distributes content on behalf of multiple content providers CDNs.
 - Two approaches for server placement:
 - i) Enter Deep**
 - ✗ The first approach is to enter deep into the access networks of ISPs.
 - ✗ Server-clusters are deployed in access networks of ISPs all over the world.
 - ✗ The goal is to get close to end users.
 - ✗ This improves delay/throughput by decreasing no. of links b/w end user & CDN cluster
 - ii) Bring Home**
 - ✗ The second approach is to bring the ISPs home.
 - ✗ Large clusters are built at a smaller number of key locations.
 - ✗ These clusters are connected using a private high-speed network.
 - ✗ Typically, clusters are placed at a location that is near the PoPs of many tier-1 ISPs.
 - For example: within a few miles of both Airtel and BSNL PoPs in a major city.
 - ✗ Advantage:
 - Lower maintenance and management overhead.
 - ✗ Disadvantage:
 - Higher delay and lower throughput to end users.



COMPUTER NETWORKS

5.2.4.3 CDN Operation

- When a browser wants to retrieve a specific video, the CDN intercepts the request.
- Then, the CDN
 - 1) determines a suitable server-cluster for the client and
 - 2) redirects the client's request to the desired server.
- Most CDNs take advantage of DNS to intercept and redirect requests.
- CDN operation is illustrated in Figure 5.2.

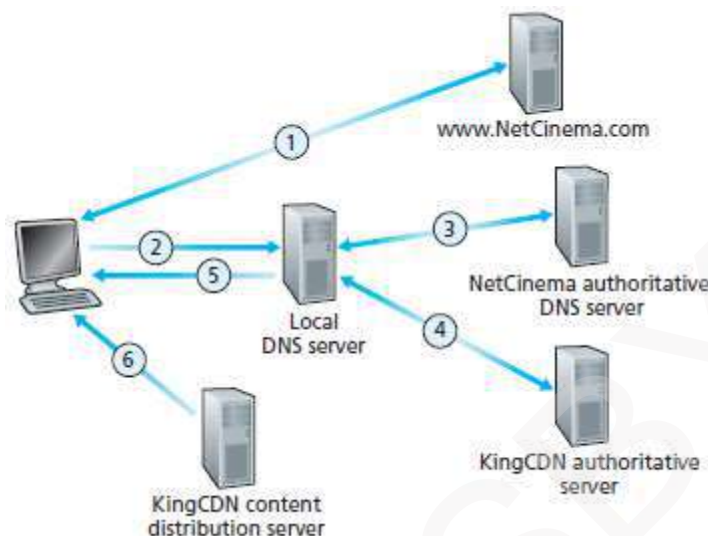

Figure 5.2: DNS redirects a user's request to a CDN server

- Suppose a content provider "NetCinema" employs the CDN company "KingCDN" to distribute videos.
- Let URL = <http://video.netcinema.com/6Y7B23V>
- Six events occur as shown in Figure 5.2:
 - 1) The user visits the Web page at NetCinema.
 - 2) The user clicks on the following link:
<http://video.netcinema.com/6Y7B23V>,
 - Then, the user's host sends a DNS query for "video.netcinema.com".
 - 3) The user's local-DNS-server (LDNS) forwards the DNS-query to an authoritative-DNS-server "NetCinema".
 - The server "NetCinema" returns to the LDNS a hostname in the KingCDN's domain.
 - For example: "a1105.kingcdn.com".
 - 4) The user's LDNS then sends a second query, now for "a1105.kingcdn.com".
 - Eventually, KingCDN's DNS system returns the IP addresses of a "KingCDN" server to LDNS.
 - 5) The LDNS forwards the IP address of the "KingCDN" server to the user's host.
 - 6) Finally, the client
 - establishes a TCP connection with the server
 - issues an HTTP GET request for the video.



COMPUTER NETWORKS

5.2.4.4 Cluster Selection Strategies

- Cluster-selection strategy is used for dynamically directing clients to a server-cluster within the CDN.
- The CDN learns the IP address of the client's LDNS server via the client's DNS lookup.
- After learning this IP address, the CDN selects an appropriate cluster based on this IP address.
- Three approaches for cluster-selection:

1) Geographically Closest

- The client is assigned to the cluster that is geographically closest.
- Using geo-location databases, each LDNS IP address is mapped to a geographic location.
- When a DNS request is received from LDNS, the CDN chooses geographically closest-cluster.
- Advantage:
 - This solution can work reasonably well for a large fraction of the clients.
- Disadvantages: The solution may perform poorly. This is because
 - 1) Geographically closest-cluster may not be the closest-cluster along the path.
 - 2) The LDNs location may be far from the client's location.

2) Based on Current Traffic Conditions

- The best cluster can be determined for a client based on the current traffic-conditions.
- CDNs perform real-time measurements of delay/loss performance b/w their clusters & clients.
- In a CDN, each cluster periodically sends probes to all of the LDNSs around the world.
- Disadvantage:
 - Many LDNSs are configured to not respond to the probes.

3) IP Anycast

- The idea behind IP anycast:
 - In Internet, the routers must route the packets to the closest-cluster, as determined by BGP.
- IP anycast is illustrated in Figure 5.3.

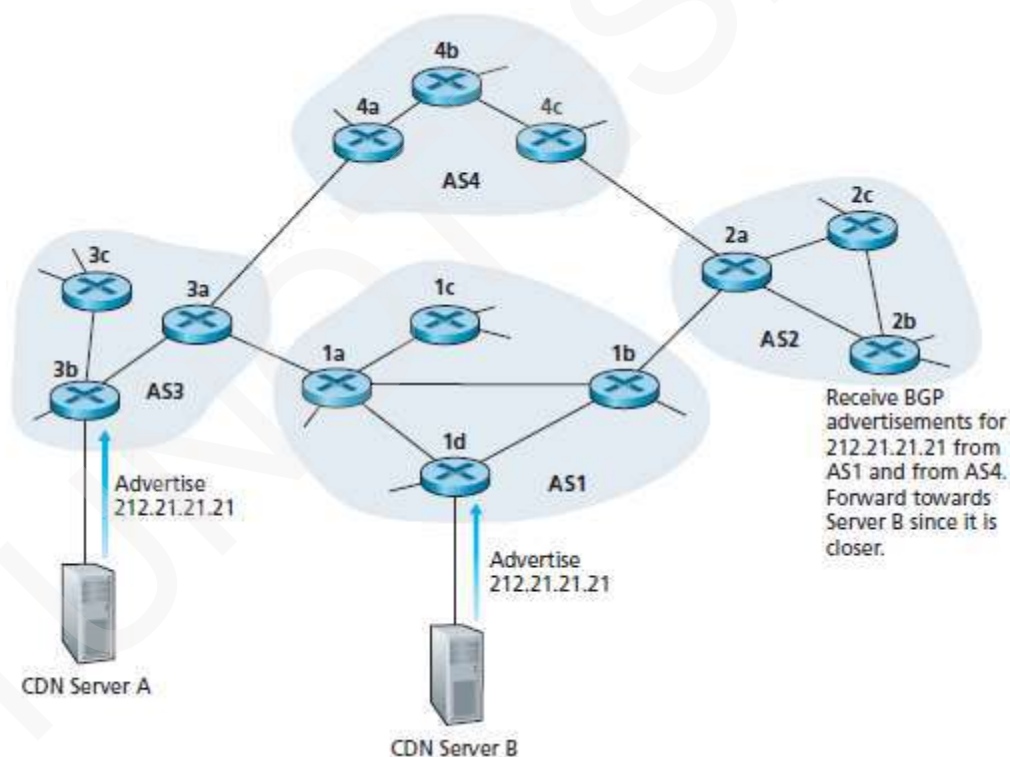

Figure 5.3: Using IP anycast to route clients to closest CDN cluster

- Here is how it works:
 - 1) During the IP-anycast configuration stage, the CDN company
 - assigns the same IP address to each clusters and
 - uses BGP to advertise the IP address from different cluster locations.
 - 2) The BGP router treats the multiple route advertisements as different paths to the same physical location.
 - 3) Then, the BGP router picks the "best" route to the IP address.



COMPUTER NETWORKS

5.3 Voice-over-IP

- Real-time voice over the Internet is often referred to as Internet telephony.
- It is also commonly called Voice-over-IP (VoIP).

5.3.1 Limitations of the Best-Effort IP Service

- The Internet's network-layer protocol IP provides best-effort service.
- The IP makes best effort to move each datagram from source to destination.
- But IP does not guarantee deliver of the packet to the destination.
- Three main challenges to the design of real-time applications:
 - 1) Packet-loss
 - 2) Packet delay and
 - 3) Packet jitter.

5.3.1.1 Packet Loss

- By default, most existing VoIP applications run over UDP.
- The UDP segment is encapsulated in an IP datagram.
- The datagram passes through router buffers in the path from sender to receiver
- Problem:
 - There is possibility that one or more buffers are full.
 - In this case, the arriving IP datagram may be discarded.
- Possible solution:
 - Loss can be eliminated by sending the packets over TCP rather than over UDP.
 - However, retransmissions are unacceptable for real-time applications \.' they increase delay.
 - Packet-loss results in a reduction of sender's transmission-rate, leading to buffer starvation.

5.3.1.2 End-to-End Delay

- End-to-end delay is the sum of following delays:
 - 1) Transmission, processing, and queuing delays in routers.
 - 2) Propagation delays in links and
 - 3) Processing delays in end-systems.
- For VoIP application,
 - delays smaller than 150 msec are not perceived by a human listener.
 - delays between 150 and 400 msec can be acceptable but are not ideal and
 - delays exceeding 400 msec can seriously hinder the interactivity in voice conversations.
- Typically, the receiving-side will discard any packets that are delayed more than a certain threshold.
- For example: more than 400 msec.

5.3.1.3 Packet Jitter

- Jitter refers to varying queuing delays that a packet experiences in the network's routers.
- If the receiver
 - ignores the presence of jitter and
 - plays out audio-chunks,then the resulting audio-quality can easily become unintelligible.
- Jitter can often be removed by using sequence numbers, timestamps, and a playout delay



COMPUTER NETWORKS

5.3.2 Removing Jitter at the Receiver for Audio

- For VoIP application, receiver must provide periodic playout of voice-chunks in presence of random jitter
- This is typically done by combining the following 2 mechanisms:
 - 1) Prepending each Chunk with a Timestamp**
 - The sender attaches each chunk with the time at which the chunk was generated.
 - 2) Delaying Playout of Chunks at the Receiver**
 - The playout delay of the received chunks must be long.
 - So, the most of the packets are received before their scheduled playout times.
 - This playout delay can either be
 - fixed throughout the duration of the session or
 - vary adaptively during the session-lifetime.



COMPUTER NETWORKS

5.3.3 Recovering from Packet Loss

- Loss recovery schemes attempt to preserve acceptable audio-quality in the presence of packet-loss.
- Here, packet-loss is defined in a 2 broad sense:
 - i) A packet is lost if the packet never arrives at the receiver or
 - ii) A packet is lost if the packet arrives after its scheduled playout time.
- VoIP applications often use loss anticipation schemes.
- Here, we consider 2 types of loss anticipation schemes:
 - 1) Forward error correction (FEC) and
 - 2) Interleaving.
- We also consider an error concealment scheme.

5.3.3.1 FEC

- The basic idea of FEC: Redundant information is added to the original packet stream.
- The redundant information can be used to reconstruct approximations of some of the lost-packets.
- Two FEC mechanisms:

1) Block Coding

- A redundant encoded chunk is sent after every n chunks.
- The redundant chunk is obtained by exclusive OR-ing the n original chunks.
- If any one packet in a group is lost, the receiver can fully reconstruct the lost-packet.
- Disadvantages:
 - 1) If 2 or more packets in a group are lost, receiver cannot reconstruct the lost-packets.
 - 2) Increases the playout delay. This is because
 - receiver must wait to receive entire group of packets before it can begin playout.

2) Lower Resolution Redundant Information

- A lower-resolution audio-stream is sent as the redundant information.
- For example: The sender creates
 - nominal audio-stream and
 - corresponding low-resolution, low-bit-rate audio-stream.
- The low-bit-rate stream is referred to as the redundant-stream.
- As shown in Figure 5.4, the sender constructs the n th packet by
 - taking the n th chunk from the nominal stream and
 - appending the n th chunk to the $(n-1)$ st chunk from the redundant-stream
- Advantage:
 - Whenever there is packet-loss, receiver can hide the loss by playing out low-bit-rate chunk.

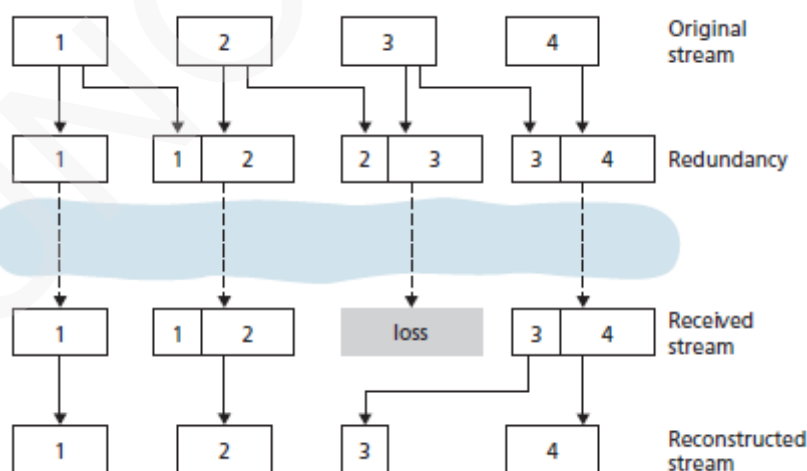

Figure 5.4: Piggybacking lower-quality redundant information



COMPUTER NETWORKS

5.3.3.2 Interleaving

- A VoIP application can send interleaved audio.
- The sender resequences units of audio-data before transmission.
- Thus, originally adjacent units are separated by a certain distance in the transmitted-stream.
- Interleaving can mitigate the effect of packet-losses.
- Interleaving is illustrated in Figure 5.5.

- For example:

If units are 5 msec in length and chunks are 20 msec (that is, four units per chunk), then

→ the first chunk contains the units 1, 5, 9, and 13

→ the second chunk contains the units 2, 6, 10 & 14 and so on.

- Advantages:

- 1) Improves the perceived quality of an audio-stream.
- 2) Low overhead.
- 3) Does not increase the bandwidth requirements of a stream.

- Disadvantage:

- 1) Increases latency. This limits use for VoIP applications.

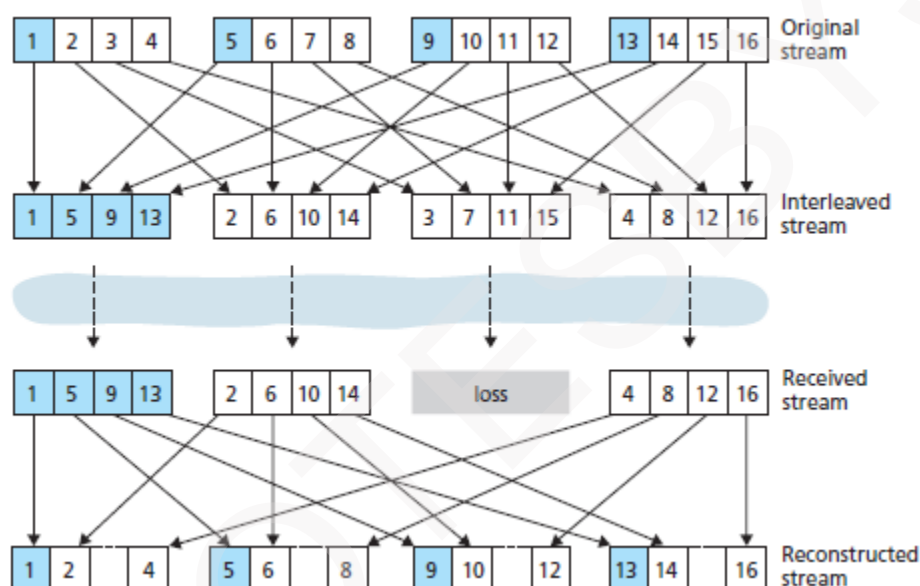

Figure 5.5: Sending interleaved audio

5.3.3.3 Error Concealment

- This scheme attempts to produce a replacement for a lost-packet that is similar to the original.
- This is possible since audio-signals exhibit large amounts of short-term self-similarity.
- Two receiver-based recovery techniques:

1) Packet Repetition

- This replaces lost-packets with copies of packets that arrived immediately before the loss.

- Advantage:

- 1) Low computational complexity.

2) Interpolation

- This uses audio before and after the loss to interpolate a suitable packet to cover the loss.

- Advantage:

- 1) Performs better than packet repetition.



COMPUTER NETWORKS

5.4 Protocols for Real-Time Conversational Applications

- Real-time applications are very popular. For ex: VoIP and video conferencing.
- Two standards bodies are working for real-time applications: 1) IETF and 2) ITU
- Both standards (IETF & ITU) are enjoying widespread implementation in industry products.

5.4.1 RTP

- RTP can be used for transporting common formats such as
 - MP3 for sound and
 - MPEG for video
- It can also be used for transporting proprietary sound and video formats.
- Today, RTP enjoys widespread implementation in many products and research prototypes.
- It is also complementary to other important real-time interactive protocols, such as SIP.

5.4.1.1 RTP Basics

- RTP runs on top of UDP.
- The RTP packet is composed of i) RTP header & ii) audio chunk
- The header includes
 - i) Type of audio encoding
 - ii) Sequence number and
 - iii) Timestamp.
- The application appends each chunk of the audio-data with an RTP header.
- Here is how it works:
 - 1) At sender-side:
 - i) A media chunk is encapsulated within an RTP packet.
 - ii) Then, the packet is encapsulated within a UDP segment.
 - iii) Finally, the UDP segment is handed over to IP.
 - 2) At receiving-side:
 - i) The RTP packet is extracted from the UDP segment.
 - ii) Then, the media chunk is extracted from the RTP packet.
 - iii) Finally, the media chunk is passed to the media-player for decoding and rendering
- If an application uses RTP then the application easily interoperates with other multimedia applications
- For example:
 - If 2 different companies use RTP in their VoIP product, then users will be able to communicate.
- What RTP does not provide?
 - i) It does not provide any mechanism to ensure timely delivery of data.
 - ii) It does not provide quality-of-service (QoS) guarantees.
 - iii) It does not guarantee delivery of packets.
 - iv) It does not prevent out-of-order delivery of packets.
- RTP encapsulation is seen only at the end systems.
- Routers do not distinguish between
 - i) IP datagrams that carry RTP packets and
 - ii) IP datagrams that don't carry RTP packets.
- RTP allows each source to be assigned its own independent RTP stream of packets.
- For example:
 - 1) For a video conference between two participants, four RTP streams will be opened
 - i) Two streams for transmitting the audio (one in each direction) and
 - ii) Two streams for transmitting the video (again, one in each direction).
 - 2) Encoding technique MPEG bundles audio & video into a single stream.
 - In this case, only one RTP stream is generated in each direction.
- RTP packets can also be sent over one-to-many and many-to-many multicast trees.



COMPUTER NETWORKS

5.4.1.2 RTP Packet Header Fields

- Four header fields of RTP Packet (Figure 5.6):
 - 1) Payload type
 - 2) Sequence number
 - 3) Timestamp and
 - 4) Source identifier.
- Header fields are illustrated in Figure 5.6.

Payload type	Sequence number	Timestamp	Synchronization source identifier	Miscellaneous fields
--------------	-----------------	-----------	-----------------------------------	----------------------

Figure 5.6: RTP header fields

Table 5.1: Audio payload types supported by RTP

Payload-Type Number	Audio Format	Sampling Rate	Rate
0	PCM μ -law	8 kHz	64 kbps
1	1016	8 kHz	4.8 kbps
3	GSM	8 kHz	13 kbps
7	LPC	8 kHz	2.4 kbps
9	G.722	16 kHz	48–64 kbps
14	MPEG Audio	90 kHz	—
15	G.728	8 kHz	16 kbps

Table 5.2: Some video payload types supported by RTP

Payload-Type Number	Video Format
26	Motion JPEG
31	H.261
32	MPEG 1 video
33	MPEG 2 video

1) Payload Type

- For an audio-stream, this field is used to indicate type of audio encoding that is being used.
 - For example: PCM, delta modulation.
 - Table 5.1 lists some of the audio payload types currently supported by RTP.
- For a video stream, this field is used to indicate the type of video encoding.
 - For example: motion JPEG, MPEG.
 - Table 5.2 lists some of the video payload types currently supported by RTP.

2) Sequence Number

- This field increments by one for each RTP packet sent.
- This field may be used by the receiver to detect packet loss and to restore packet sequence.

3) Timestamp

- This field reflects the sampling instant of the first byte in the RTP data packet.
- The receiver can use timestamps
 - to remove packet jitter in the network and
 - to provide synchronous playout at the receiver.
- The timestamp is derived from a sampling clock at the sender.

4) Source Identifier (SRC)

- This field identifies the source of the RTP stream.
- Typically, each stream in an RTP session has a distinct SRC.



COMPUTER NETWORKS

5.4.2 SIP

- SIP (Session Initiation Protocol) is an open and lightweight protocol.
- Main functions of SIP:
 - 1) It provides mechanisms for establishing calls b/w a caller and a callee over an IP network.
 - 2) It allows the caller to notify the callee that it wants to start a call.
 - 3) It allows the participants to agree on media encodings.
 - 4) It also allows participants to end calls.
 - 5) It provides mechanisms for the caller to determine the current IP address of the callee.
 - 6) It provides mechanisms for call management, such as
 - adding new media streams during the call
 - changing the encoding during the call
 - inviting new participants during the call,
 - call transfer and
 - call holding.



COMPUTER NETWORKS

5.4.2.1 Setting up a Call to a Known IP Address

- SIP call-establishment process is illustrated in Figure 5.7.

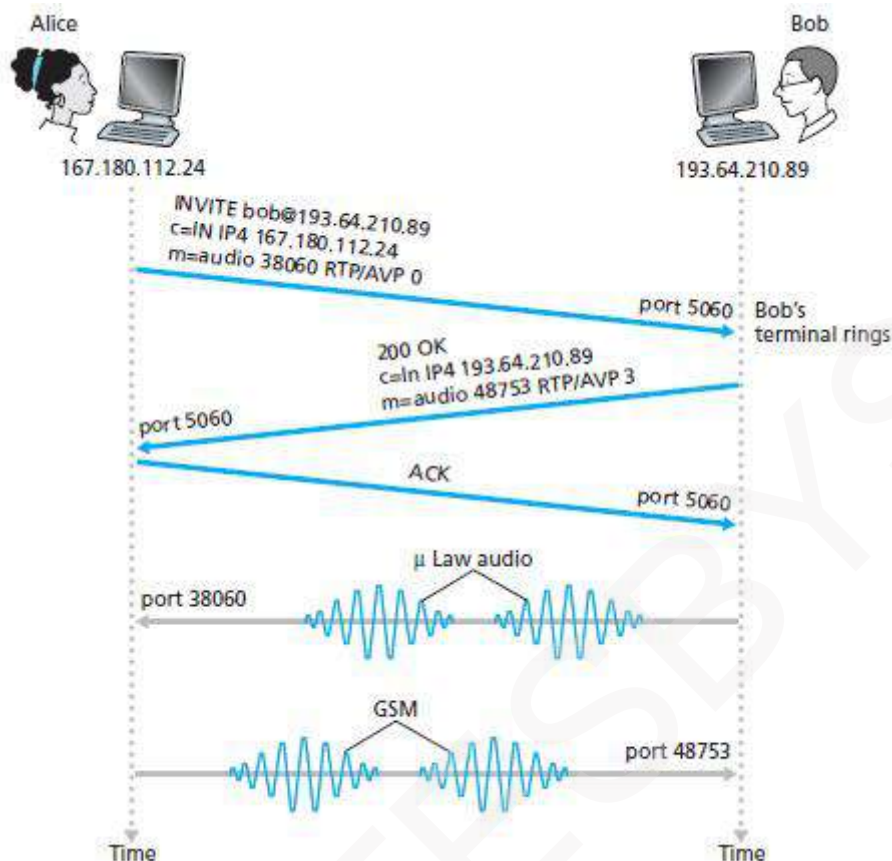

Figure 5.7: SIP call establishment when Alice knows Bob's IP address

- Consider an example: Alice wants to call Bob.
- Alice's & Bob's PCs are both equipped with SIP-based software for making and receiving phone calls.
- The following events occur:
 - 1) An SIP session begins when Alice sends Bob an INVITE message.
 - This INVITE message is sent over UDP to the well-known port 5060 for SIP.
 - The INVITE message includes
 - i) An identifier for Bob (bob@193.64.210.89)
 - ii) An indication of Alice's current IP address
 - iii) An indication that Alice desires to receive audio, which is encoded in format AVP 0.
 - 2) Then, Bob sends an SIP response message (which resembles an HTTP response message).
 - The response message is sent over UDP to the well-known port 5060 for SIP.
 - The response message includes
 - i) 200 OK
 - ii) An indication of Bob's current IP address
 - iii) An indication that Bob desires to receive audio, which is encoded in format AVP 3.
 - 3) Then, Alice sends Bob an SIP acknowledgment message.
 - 4) Finally, Bob and Alice can talk.
- Three key characteristics of SIP:
 - 1) SIP is an out-of-band protocol
 - The SIP message & the media-data use different sockets for sending and receiving.
 - 2) The SIP messages are ASCII-readable and resemble HTTP messages.
 - 3) SIP requires all messages to be acknowledged, so it can run over UDP or TCP.



COMPUTER NETWORKS

5.4.2.2 SIP Messages

- Suppose that Alice wants to initiate a VoIP call to Bob.
- Then, her message will look something like this:

```
L1) INVITE sip:bob@domain.com SIP/2.0
L2) Via: SIP/2.0/UDP 167.180.112.24
L3) From: sip:alice@hereway.com
L4) To: sip:bob@domain.com
L5) Call-ID: a2e3a@pigeon.hereway.com
L6) Content-Type: application/sdp
L7) Content-Length: 885
L8) c=IN IP4 167.180.112.24
L9) m=audio 38060 RTP/AVP 0
```

- Line by line explanation is as follows:
 - L1) The INVITE line includes the SIP version.
 - L2) Via header indicates the IP address of the SIP device.
 - L3) Similar to an e-mail message, the SIP message includes a From header line.
 - L4) Similar to an e-mail message, the SIP message includes a To header line.
 - L5) Call-ID uniquely identifies the call.
 - L6) Content-Type defines the format used to describe the message-content.
 - L7) Content-Length provides the length in bytes of the message-content.
 - L8) A carriage return followed by line feed.
 - L9) The message contains the content.



COMPUTER NETWORKS

5.4.2.3 Name Translation & User Location

- IP addresses are often dynamically assigned with DHCP.
- Suppose that Alice knows only Bob's e-mail address, bob@domain.com
- In this case, Alice needs to obtain the IP address of the device associated with the bob@domain.com.
- How to find IP address?
 - 1) Alice creates & sends an INVITE message to an SIP proxy.
 - 2) The proxy responds with an SIP reply.
 - The reply includes the IP address of the device associated with the bob@domain.com.
- How can the proxy server determine the current IP address for bob@domain.com?

Answer: Every SIP user has an associated registrar.

- First, a user launches an SIP application on a device.
- Then, the application sends an SIP register message to the registrar.
- Finally, IP address of the device will be registered in the registrar.
- The user's registrar keeps track of his current IP address.
- When the user switches to a new device, IP address of new device will be registered in the registrar.
- The registrar is analogous to a DNS authoritative name server:
 - 1) The DNS server translates fixed host names to fixed IP addresses;
 - 2) The SIP registrar translates human identifiers (ex: bob@domain.com) to dynamic IP address.

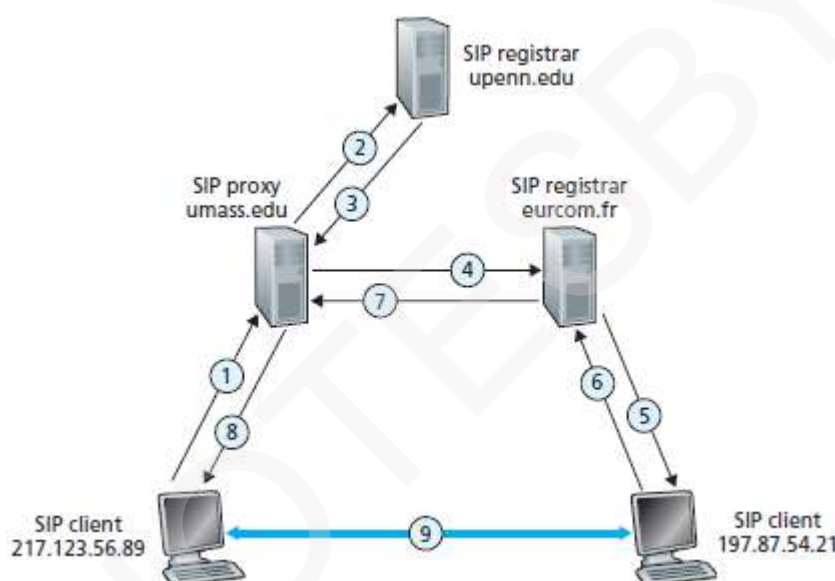

Figure 5.8: Session initiation, involving SIP proxies and registrars

- Session initiation process is illustrated in Figure 5.8.
- jim@umass.edu (217.123.56.89) wants to initiate VoIP session with keith@upenn.edu (197.87.54.21)
- The following steps are taken:
 - 1) Jim sends an INVITE message to the umass SIP proxy.
 - 2) The proxy
 - performs DNS lookup on the SIP registrar upenn.edu and
 - forwards then the message to the registrar server upenn.
 - 3) keith@upenn.edu is not registered at the upenn registrar.
 - Therefore, the upenn registrar sends a redirect response to umass proxy.
 - 4) The umass proxy sends an INVITE message to the eurecom SIP registrar.
 - 5) The eurecom registrar
 - knows the IP address of keith@eurecom.fr and
 - forwards INVITE message to the host 197.87.54.21 which is running Keith's SIP client.
 - 6-8) An SIP response is sent back through registrars/proxies to SIP client on 217.123.56.89.
 - 9) Media is sent directly between the two clients.



COMPUTER NETWORKS

5.5 Network Support for Multimedia

- Table 5.3 summarizes 3 approaches to provide network-level support for multimedia applications.

1) Making the Best of Best-effort Service

- The application-level mechanisms can be successfully used in a n/w where packet-loss rarely occur.
- When demand increases are forecasted, ISPs can deploy additional bandwidth & switching capacity.
- This ensures satisfactory delay and packet-loss performance.

2) Differentiated Service

- In this, one traffic-type can be given priority over another one when both are queued at a router
- For ex:

Packets belonging to a real-time application can be given priority over non-real-time application.

3) Per-connection QoS Guarantees

- In this, each instance of an application explicitly reserves end-to-end bandwidth.
- Thus, end-to-end performance is guaranteed.
 - i) A hard guarantee means the application will receive its requested QoS with certainty.
 - ii) A soft guarantee means the application will receive its requested QoS with high probability.

Table 5.3: Three network-level approaches to supporting multimedia applications

Approach	Granularity	Guarantee	Mechanisms	Complexity	Deployment to date
Making the best of best-effort service.	all traffic treated equally	none, or soft	application-layer support, CDNs, overlays, network-level resource provisioning	minimal	everywhere
Differentiated service	different classes of traffic treated differently	none, or soft	packet marking, policing, scheduling	medium	some
Per-connection Quality-of-Service (QoS) Guarantees	each source-destination flows treated differently	soft or hard, once flow is admitted	packet marking, policing, scheduling; call admission and signaling	light	little



COMPUTER NETWORKS

5.5.1 Dimensioning Best Effort Networks

- Bandwidth-provisioning is defined as
 - “The bandwidth capacity required at network links to achieve a given performance.”
- Network dimensioning is defined as
 - “The design of a network topology to achieve a given performance.”
- Three issues must be addressed to achieve a given performance:
 - 1) Models of traffic demand between network end points.
- Models have to be specified at both the call-level and at the packet-level.
 - i) Example for call level: Users arriving to the network and starting up end-to-end applications.
 - ii) Example for packet level: Packets being generated by ongoing applications.
- 2) Well-defined performance requirements.
- For example
 - Consider delay-sensitive traffic, such as a conversational multimedia application.
 - Here, a performance requirement can be:
 - probability the end-to-end delay of the packet is greater than a maximum tolerable delay
- 3) Models to predict end-to-end performance for a given workload model.
- Techniques to find a least cost bandwidth allocation that results in all user requirements being met.



COMPUTER NETWORKS

5.5.2 Providing Multiple Classes of Service

- The traffic can be divided into different classes.
- Different priority can be provided to the different traffic-classes.
- For example:
 - ISP provides a higher priority to delay-sensitive VoIP traffic than to elastic traffic email/HTTP.

5.5.2.1 Motivating Scenarios

- Figure 5.9 shows a simple network scenario.
- Here, two flows
 - originate on Hosts H1 & H2 on one LAN and
 - are destined for Hosts H3 and H4 on another LAN.
- The routers on the two LANs are connected by a 1.5 Mbps link.

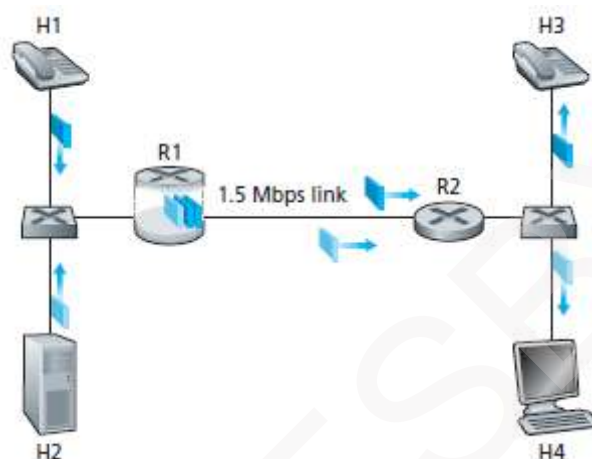

Figure 5.9: Competing audio and HTTP applications

- Consider the best-effort Internet.
- At output-queue of R1, the audio and HTTP packets are mixed & transmitted in a FIFO order.
- Problem: HTTP packet from Web-server fills up the queue. This causes delay/loss of audio packets.
- Solution:
 - Use a priority scheduling discipline.
 - Here, an audio packet will always be transmitted before HTTP packets.

Insight 1:

- Packet marking allows a router to distinguish among packets belonging to different classes of traffic.
- If audio application starts sending packets at 1.5 Mbps or higher, then the HTTP packets will starve.

Insight 2:

- It is desirable to provide a degree of traffic isolation among classes.
- Thus, one class is not adversely affected by another class of traffic that misbehaves.



COMPUTER NETWORKS

5.5.2.1.1 Approaches for Providing Isolation among Traffic Classes

- Two approaches:
 - 1) Traffic policing can be performed.
 - 2) Packet-scheduling mechanism explicitly allocates a fixed amount of bandwidth to each class.

5.5.2.1.1.1 Using Traffic Policing

- Traffic policing can be performed. This scenario is shown in Figure 5.10.
- If a traffic class meets certain criteria, then a policing mechanism ensures that these criteria are observed. (For example: the audio flow should not exceed a peak-rate of 1 Mbps).
- If the policed application misbehaves, the policing mechanism will take some action. (For example: drop or delay packets that are in violation of the criteria)
- The leaky bucket mechanism is the most widely used policing mechanism.
- This scenario is shown in Figure 5.10.

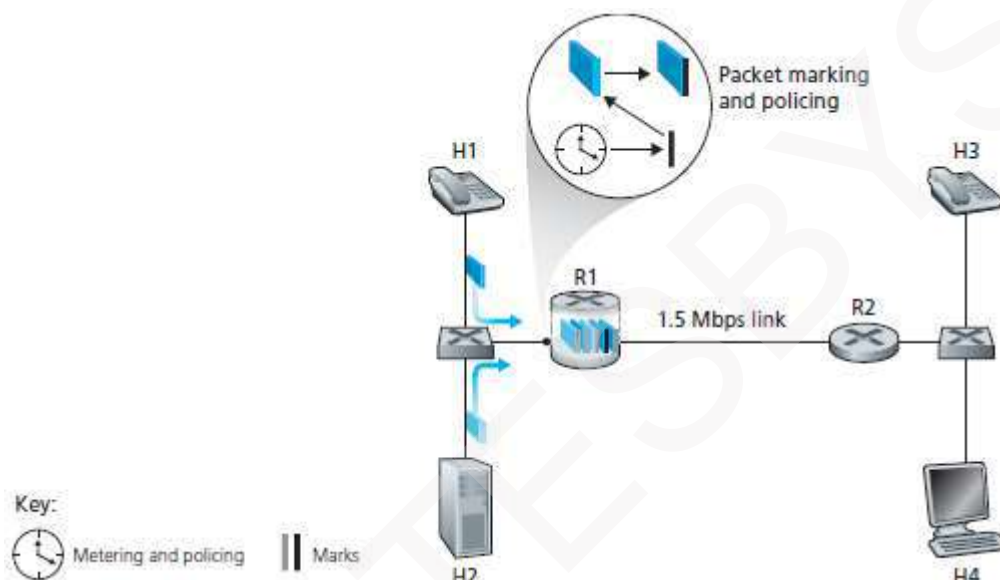

Figure 5.10: Policing (and marking) the audio and HTTP traffic classes

5.5.2.1.1.2 Using Packet Scheduling

- Packet-scheduling mechanism explicitly allocates a fixed amount of bandwidth to each class.
- For example:
 - the audio class will be allocated 1 Mbps at R1
 - the HTTP class will be allocated 0.5 Mbps.
- This scenario is shown in Figure 5.11.

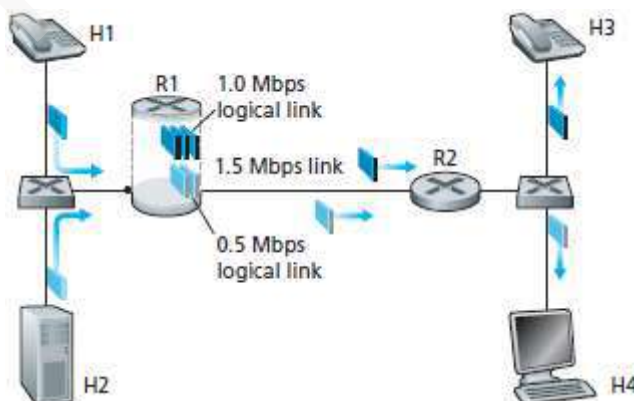

Figure 5.11: Logical isolation of audio and HTTP traffic classes

Insight 3:

- While providing isolation among classes, it is desirable to use resources as efficiently as possible.

"Life is a learning process; learning is a lifelong process. You cant separate them." -Vivienne Forrester



COMPUTER NETWORKS

5.5.2.2 Scheduling Mechanisms

- Queue-scheduling refers to
"The manner in which queued packets are selected for transmission on the link."

5.5.2.2.1 FIFO

- FIFO (First-In-First-Out) is illustrated in Figure 5.12 & Figure 5.13.
 - Packets are transmitted in order of their arrival at the queue.
 - Packets arriving at the queue wait for transmission if the link is currently busy.
 - Packets are discarded when they arrive at a full buffer.
 - When a packet is completely transmitted over outgoing-link, the packet is removed from the queue.
 - Disadvantages:
 - 1) This is not possible to provide different information flows with different QoS.
 - 2) Hogging occurs when a user
 - sends packets at a high rate and
 - fills the buffers in the system
- Thus, depriving other users of access to the buffer.

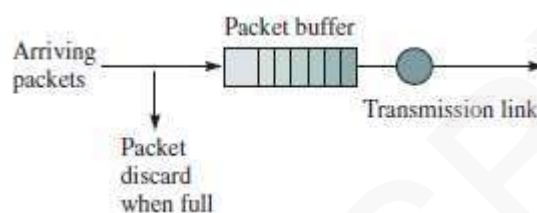

Figure 5.12: FIFO queuing

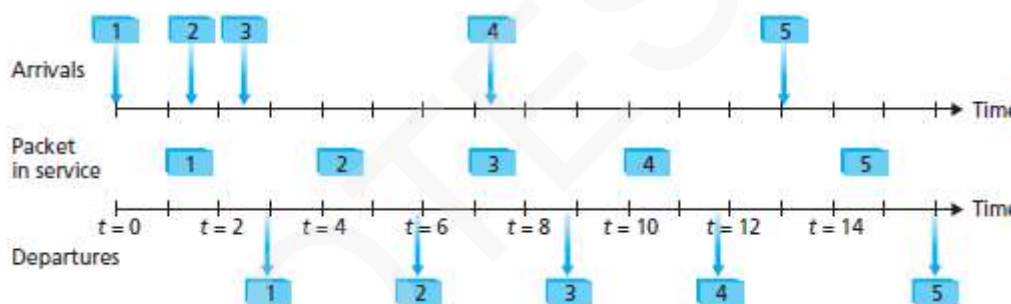

Figure 5.13: Operation of the FIFO queue



COMPUTER NETWORKS

5.5.2.2.2 Priority Queuing

- PQ (Priority Queuing) is illustrated in Figure 5.14 & Figure 5.15.
- Number of priority classes is defined.
- A separate buffer is maintained for each priority class.
- Each time the transmission link becomes available, the next packet for transmission is selected from the highest priority queue.
- Typically, the choice among packets in the same priority-class is done in a FIFO manner.
- In a non-preemptive PQ, the transmission of a packet is not interrupted once it has begun.
- Disadvantages:
 - 1) This does not discriminate among users of the same priority.
 - 2) This does not allow for providing some degree of guaranteed access to transmission bandwidth to the lower priority classes.
 - 3) Hogging occurs.

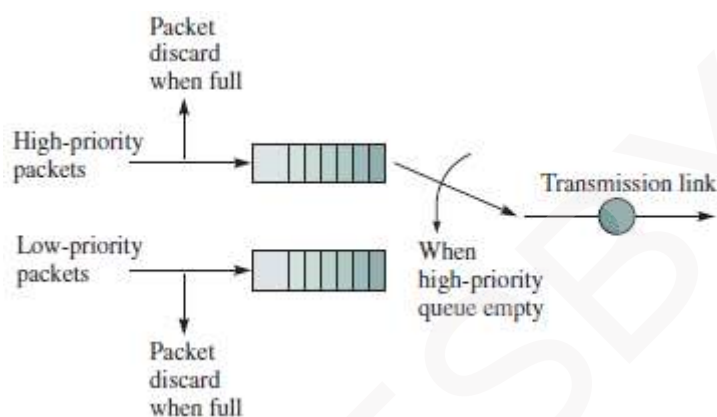

Figure 5.14 : Priority Queueing

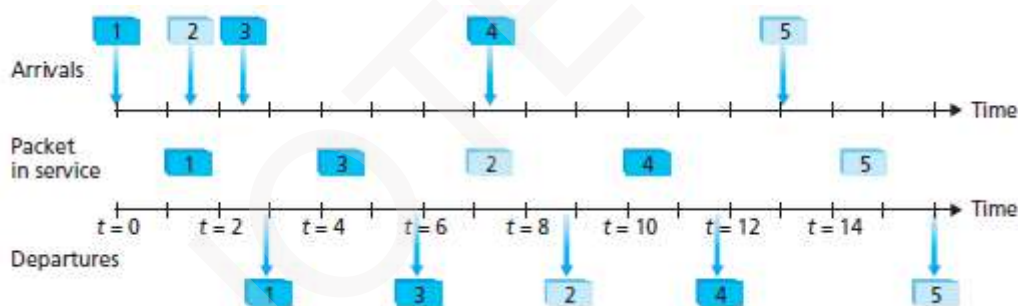

Figure 5.15: Operation of the priority queue

COMPUTER NETWORKS

5.5.2.2.3 RRQ

- RRQ (Round Robin Queuing) is illustrated in Figure 5.16 & Figure 5.17.
- The transmission bandwidth is divided equally among the buffers.
- Each user flow has its own logical buffer.
- Round-robin scheduling is used to service each non-empty buffer one bit at a time.
- In the simplest form, a class 1 packet is transmitted, followed by a class 2 packet, followed by a class 1 packet, followed by a class 2 packet, and so on.
- RRQ is a work-conserving queuing discipline.
- Thus, RRQ will immediately move on to the next class when it finds an empty queue.
- Disadvantage: Extensive processing at the destination.

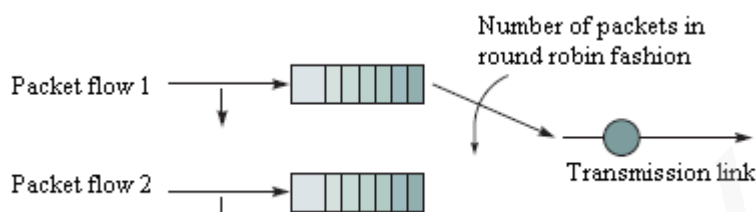

Figure 5.16: Round-robin queuing

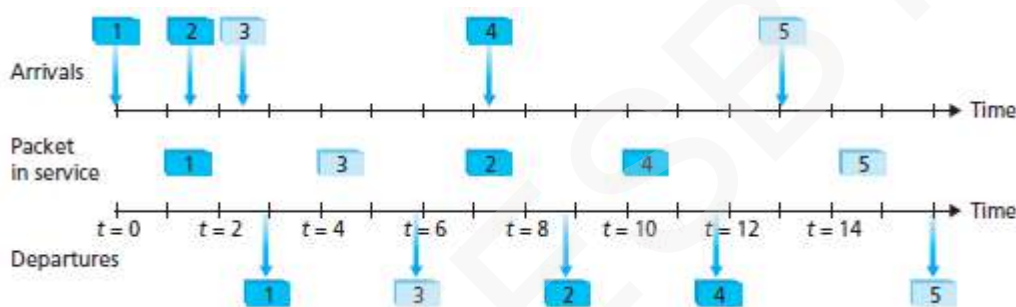

Figure 5.17: Operation of the two-class round robin queue

5.5.2.2.4 WFQ

- WFQ (Weighted Fair Queuing) is illustrated in Figure 5.18.
- Each user flow has its own buffer, but each user flow also has a weight that determines its relative share of the bandwidth.
- If buffer 1 has weight 1 and buffer 2 has weight 3, then buffer 1 will receive 1/4 of the bandwidth and buffer 2 will receive 3/4 of the bandwidth.
- In each round, each non-empty buffer would transmit a number of packets proportional to its weight.
- WFQ systems are means for providing QoS guarantees.
- WFQ is also a work-conserving queuing discipline.
- Thus, WFQ will immediately move on to the next class when it finds an empty queue.

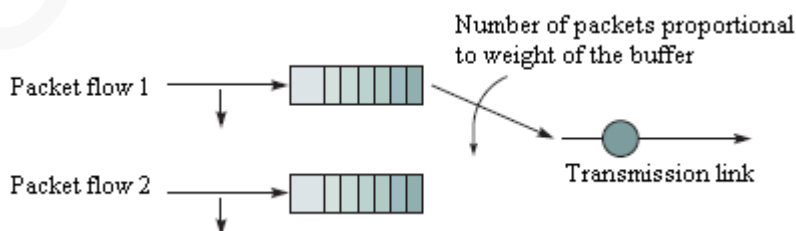

Figure 5.18: Weighted fair queuing



COMPUTER NETWORKS

5.5.2.3 Policing: The Leaky Bucket

- Policing is an important QoS mechanism
- Policing means the regulation of the rate at which a flow is allowed to inject packets into the network.
- Three important policing criteria:
 - 1) **Average Rate**
 - This constraint limits amount of traffic that can be sent into n/w over a long period of time.
 - 2) **Peak Rate**
 - This constraint limits maximum no. of packets that can be sent over a short period of time
 - 3) **Burst Size**
 - This constraint limits the maximum no. of packets that can be sent into n/w over a very short period of time.

5.5.2.3.1 Leaky Bucket Operation

- Policing-device can be implemented based on the concept of a leaky bucket.
- Tokens are generated periodically at a constant rate.
- Tokens are stored in a bucket.
- A packet from the buffer can be taken out only if a token in the bucket can be drawn.
- If the bucket is full of tokens, additional tokens are discarded.
- If the bucket is empty, arriving packets have to wait in the buffer until a sufficient no. of tokens is generated.

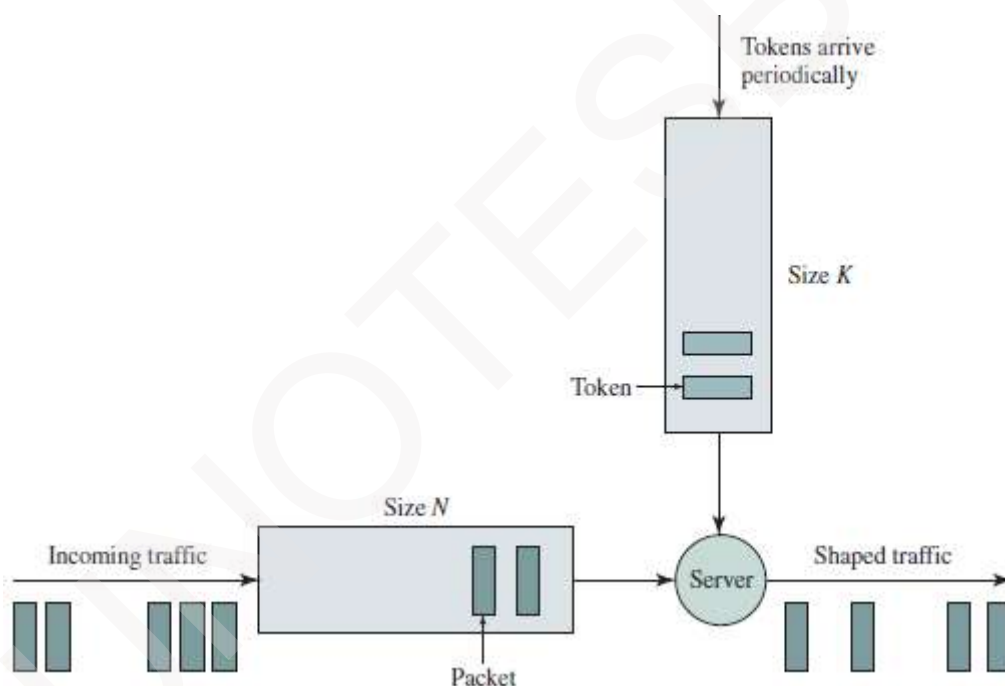

Figure 5.19: The leaky bucket policer



COMPUTER NETWORKS

5.5.3 DiffServ

- This provides QoS support to a broad class of applications.
- This provides service differentiation.
- Differentiation is defined as
“The ability to handle different classes of traffic in different ways within the Internet”.

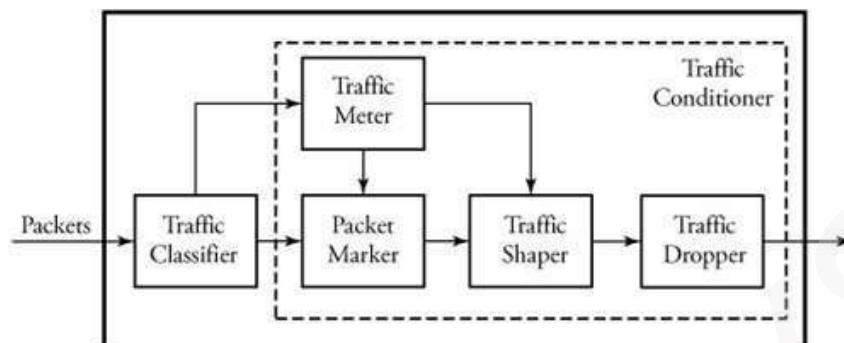

Figure 5.21: Overview of DiffServ operation

- The Diffserv architecture consists of 2 functional elements:

1) Packet Classification & Traffic Conditioning

- The traffic-classifier routes packets to specific outputs, based on the values of one or more header-fields.
- The traffic-profile contains a limit on the peak-rate of the flow.
- The traffic-conditioner detects and responds if any packet has violated the negotiated traffic-profile.
- The traffic-conditioner has 4 major components:
 - i) Meter**
 - The meter measures the traffic to make sure that packets do not exceed their traffic profiles
 - ii) Marker**
 - The marker marks or unmarks packets in order to keep track of their situations in the Diffserv node.
 - iii) Shaper**
 - The shaper delays any packet that is not complaint with the traffic-profile
 - iv) Dropper**
 - The dropper discards any packet that violates its traffic-profile

2) Core Function: Forwarding

- The per-hop behavior (PHB) is performed by Diffserv-capable routers.
- A router forwards marked-packet onto its next hop according to the PHB (per-hop behavior).
- PHB influences how network-resources are shared among the competing classes of traffic.
- Two types of PHB are: i) expedited forwarding and ii) assured forwarding.
 - i) Expedited Forwarding (EF) PHB**
 - This specifies that the departure rate of a class of traffic from a router must equal or exceed a configured rate.
 - ii) Assured Forwarding (AF) PHB**
 - This divides traffic into 3 classes: good, average and poor.
 - Here, each class is guaranteed to be provided with some minimum amount of bandwidth and buffering.
- PHB is defined as
“A description of the externally observable forwarding behavior of a Diffserv node applied to a particular Diffserv behavior aggregate”
- From above definition, we have 3 considerations:
 - i) A PHB can result in different classes of traffic receiving different performance.
 - ii) A PHB does not dictate any particular mechanism for differentiating performance (behavior) among classes.
 - iii) Differences in performance must be observable and hence measurable.



COMPUTER NETWORKS

5.5.4 Per-Connection QoS Guarantees: Resource Reservation & Call Admission

- Consider two 1 Mbps audio applications transmitting their packets over 1.5 Mbps link (Figure 5.22).
- The combined data-rate of the two flows (2 Mbps) exceeds the link capacity.
- There is lesser bandwidth to accommodate the needs of both applications at the same time.
- Problem: What should the network do?

Answer:

- One of the applications should be allowed to use the full 1 Mbps.
- While the other application flows should be blocked.
- For example:
 - In telephone n/w, if the required resources cannot be allocated to the call, the call is blocked.

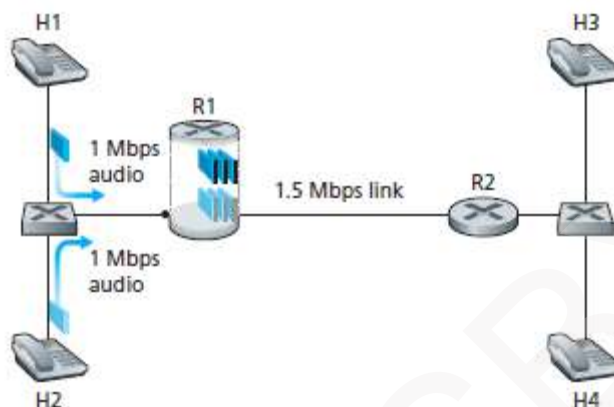

Figure 5.22: Two competing audio applications overloading R1-to-R2 link

- Admission process is defined as
The process of declaring flow's QoS requirement, & then deciding either to accept or block the flow.

Insight 4:

- If sufficient resources are not available, and QoS is to be guaranteed, a call admission process is needed to decide whether to accept or block the flow.

COMPUTER NETWORKS

5.5.4.1 Mechanisms for Guaranteed QoS

- Three mechanisms to provide guaranteed QoS:

1) Resource Reservation

- The resources are explicitly allocated to the call to meet the desired QoS.
- After reservation, the call has on-demand access to the resources throughout its duration.

2) Call Admission

- The network must have a mechanism for calls to request & reserve resources.
- If the requested resources are not available, the call will be blocked.
- Such a call admission is performed by the telephone network.
- For ex: In telephone network, we request resources when we dial a number.
 - i) If the required resources are allocated, the call is completed.
 - ii) If the required resources cannot be allocated, the call is blocked.

3) Call Setup Signaling

- A signaling protocol can be used to coordinate following activities.
 - 1) The per-hop allocation of local resources (Figure 5.23)
 - 2) The overall end-to-end decision of whether or not the call has been able to reserve sufficient resources at each and every router on the end-to-end path.
- The RSVP protocol is a call setup protocol for providing QoS guarantees.

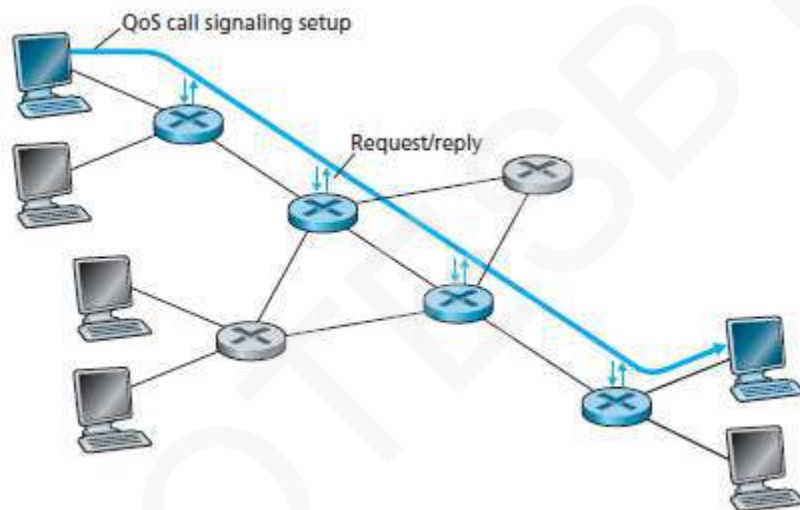

Figure 5.23: The call setup process

**MODULE-WISE QUESTIONS****PART 1**

- 1) Briefly explain properties of Video. (4*)
- 2) Briefly explain properties of Audio. (4)
- 3) Briefly explain three broad categories of multimedia network applications. (6*)
- 4) Briefly explain UDP streaming stored video application. (4*)
- 5) With a diagram, explain streaming stored video over HTTP/TCP. (6*)
- 6) Briefly explain adaptive streaming & DASH. (6*)
- 7) Briefly explain CDN, its motivation & its type. (6)
- 8) With a diagram, explain CDN Operation. (6*)
- 9) Briefly explain three approaches for cluster-selection. (6)
- 10) List out and explain three challenges to the design of real-time applications. (6)
- 11) Briefly explain two FEC mechanisms. (6*)
- 12) With a diagram, explain interleaving. (6*)

PART 2

- 13) Briefly explain RTP & its services. (4*)
- 14) With general format, explain various field of RTP. (6*)
- 15) Briefly explain SIP & its services. (4)
- 16) With a diagram, explain SIP call establishment. (6*)
- 17) With a diagram, explain SIP name translation & user location. (6)
- 18) Briefly explain three approaches to provide network-level support for multimedia applications. (6*)
- 19) Briefly explain dimensioning best effort networks. (6)
- 20) Briefly explain 2 approaches for providing isolation among traffic classes. (6)
- 21) With a diagram for each, explain FIFO and priority queue scheduling. (8*)
- 22) With a diagram for each, explain RRQ and WFQ scheduling. (8*)
- 23) With a diagram, explain the working of leaky bucket. (6*)
- 24) With a diagram, explain various components of DiffServ. (6*)
- 25) Briefly explain three mechanisms for guaranteed QoS. (6*)