

## Module – 3

### Introduction

#### Structure

- 3.0 Introduction
- 3.1 Objectives
- 3.2 Sampling
- 3.3 Characteristics of wastewater
- 3.4 Flow diagram for municipal waste water treatment
- 3.5 Unit operations
- 3.6 Trickling filters
- 3.7 Activated sludge process
- 3.8 Sequential batch reactors
- 3.9 Moving bed bio reactors
- 3.10 Sludge digesters
- 3.11 Recommended questions
- 3.12 Outcomes
- 3.13 Further Reading

#### 3.0 Introduction

The objective of sampling is to collect representative sample. Representative sample by means a sample in which relative proportions or concentration of all pertinent components will be the same as in the material being sampled. Moreover, the same sample will be handled in such a way that no significant changes in composition occur before the tests are made. The sample volume shall optimal small enough that it can be transported and large enough for analytical purposes. Because of the increasing placed on verifying the accuracy and representatives of data, greater emphasis is placed on proper sample collection, tracking, and preservation techniques. Often laboratory personnel help in planning a sampling program, in consultation with the user of the test results. Such consultation is essential to ensure selecting samples and analytical methods that provide a sound and valid basis for answering the questions that prompted the sampling and that will meet regulatory and/or project-specific requirements.

#### 3.1 Objectives

- Understand and design different unit operations involved in conventional and biological treatment process.

#### 3.2 Sampling:

The objective of sampling is to collect representative sample. Representative sample by means a sample in which relative proportions or concentration of all pertinent components will be the same as in the material being sampled. Moreover, the same sample will be handled in such a way that no significant changes in composition occur before the tests are made. The sample volume shall optimal small enough that it can be transported and large enough for analytical purposes. Because of the increasing placed on verifying the accuracy

and representatives of data, greater emphasis is placed on proper sample collection, tracking, and preservation techniques. Often laboratory personnel help in planning a sampling program, in consultation with the user of the test results. Such consultation is essential to ensure selecting samples and analytical methods that provide a sound and valid basis for answering the questions that prompted the sampling and that will meet regulatory and/or project-specific requirements.

The objectives and significance must be clearly understood when environmental sampling is carried out. Field records and analysis data obtained using analytical instruments are required if we are to correctly evaluate the environmental situation, and such data must be representative of the environment. In order to obtain accurate environmental data, it is imperative that the analysis samples be representative. However, they are not particularly easy to collect, so can only be accumulated through appropriate planning and implementation of sampling.

In terms of types of aquatic sampling, we include river water, seawater, and factory effluent sampling. With regard to air sampling, we look at flue gases from factories and vehicles, as well as ambient air sampling. Sometimes riverbeds are also sampled.

As stated before, the most important issue when drawing up a plan for sampling is to clearly understand its significance and objectives. In other words, we must correctly determine how, why, and what to conduct the survey on. Furthermore, sampling work should be undertaken according to specified procedures. In this case, it is important to use samplers and sample containers that are suited to the task.

Regular surveys are required to provide successive sampling analysis data in order to identify environmental changes, so such sampling must be consistent in its methodology and location. A very high degree of accuracy is required when undertaking sampling to determine whether the law is being met. When sampling under accident conditions, data should be obtained to accurately establish the cause(s) and evaluate the state of the site in order to discuss appropriate countermeasures.

### 3.2.1 Sampling Techniques

Two types of sampling techniques are used: grab and composite.

**Grab samples:** Grab samples are single collected at a specific spot at a site over a short period of time (typically seconds or minutes). Thus, they represent a snapshot in both space and time of a sampling area. Discrete grab samples are taken at a selected location, depth, and time. Depth-integrated grab samples are collected over a predetermined part of the entire depth of a water column, at a selected location and time in a given body of water. Grab samples consist of either a single discrete sample or individual samples collected over a period of time not to exceed 15 minutes. The grab sample should be representative of the wastewater conditions at the time of sample collection. The sample volume depends on the type and number of analyses to be performed. A sample can represent only the composition of its source at the time and place of collection. However, when a source is known to be relatively constant in composition over an extended time or over substantial distances in all directions, then the sample may represent a longer time period and/or a larger volume than the specific time and place at which it was collected. In such circumstances, a source may be represented adequately by single grab samples. Examples are protected groundwater supplies,

water supplies receiving conventional treatment, some well-mixed surface waters, but rarely, wastewater streams, rivers, large lakes, shorelines, estuaries, and groundwater plumes. When a source is known to vary with time, grab samples collected at suitable intervals and analyzed separately can document the extent, frequency, and duration of these variations. Choose sampling intervals on the basis of the expected frequency of changes, which may vary from as little as 5 min to as long as 1h or more. Seasonal variations in natural systems may necessitate sampling over months. When the source composition varies in space (i.e. from location to location) rather than time, collect samples from appropriate locations that will meet the objectives of the study (for example, upstream and downstream from a point source, etc.).

**Composite samples:** Composite samples should provide a more representative sampling of heterogeneous matrices in which the concentration of the analytes of interest may vary over short periods of time and/or space. Composite samples can be obtained by combining portions of multiple grab samples or by using specially designed automatic sampling devices. Sequential (time) composite samples are collected by using continuous, constant sample pumping or by mixing equal water volumes collected at regular time intervals. Flow-proportional composites are collected by continuous pumping at a rate proportional to the flow, by mixing equal volumes of water collected at time intervals that are inversely proportional to the volume of flow, or by mixing volumes of water proportional to the flow collected during or at regular time intervals. Advantages of composite samples include reduced costs of analyzing a large number of samples, more representative samples of heterogeneous matrices, and larger sample sizes when amounts of test samples are limited. Disadvantages of composite samples include loss of analyte relationships in individual samples, potential dilution of analytes below detection levels, increased potential analytical interferences, and increased possibility of analyte interactions. In addition, use of composite samples may reduce the number of samples analyzed below the required statistical need for specified data quality objectives or project-specific objectives.

Do not use composite samples with components or characteristics subject to significant and unavoidable changes during storage. Analyze individual samples as soon as possible after collection and preferably at the sampling point. Examples are dissolved gases, residual chlorine, soluble sulphide, temperature, and pH. Changes in components such as dissolved oxygen or carbon dioxide, pH, or temperature may produce secondary changes in certain inorganic constituents such as iron, manganese, alkalinity, or hardness. Some organic analytes also may be changed by changes in the foregoing components. Use time-composite samples only for determining components that can be demonstrated to remain unchanged under the conditions of sample collection, preservation, and storage. Collect individual portions in a wide-mouth bottle every hour (in some cases every half hour or even every 5 min) and mix at the end of the sampling period or combine in a single bottle as collected. If preservatives are used, add them to the sample bottle initially so that all portions of the composite are preserved as soon as collected. Automatic sampling devices are available; however, do not use them unless the sample is preserved as described below. Composite samplers running for extended periods (week to months) should undergo routine cleaning of containers and sample lines to minimize sample growth and deposits. Composite samples are

collected over time, either by continuous sampling or by mixing discrete samples. A composite sample represents the average wastewater characteristics during the compositing period. Various methods for compositing are available and are based on either time or flow proportioning. The choice of a flow proportional or time composite sampling scheme depends on the permit requirements, variability of the wastewater flow or concentration of pollutants, equipment availability and sampling location. The investigator must know each of these criteria before a sampling program can be initiated. Generally, a time composite is acceptable. However, in enforcement cases where strict adherence to permit requirements are necessary, a flow proportional sample is preferable, if possible. A time composite sample consists of equal volume discrete sample aliquots collected at constant time intervals into one container. A time composite sample can be collected either manually or with an automatic sampler. A flow proportional composite sample can be collected using one of two methods. One method consists of collecting a constant sample volume at varying time intervals proportional to the wastewater flow. For the other method, the sample is collected by varying the volume of each individual aliquot proportional to the flow, while maintaining a constant time interval between the aliquots. Flow proportional samples can be collected directly with an automatic sampler that is connected to a compatible flow measuring device. An automatic sampler can also be used to collect discrete samples.

**Integrated (discharge-weighted) samples:** For certain purposes, the information needed is best provided by analyzing mixtures of grab samples collected from different points simultaneously, or as nearly so as possible, using discharge-weighted methods such as equal-width increment (EWI) or equal discharge-increment (EDI) procedures and equipment. An example of the need for integrated sampling occurs in a river or stream that varies in composition across its width and depth. To evaluate average composition or total loading, use a mixture of samples representing various points in the cross-section, in proportion to their relative flows. The need for integrated samples also may exist if combined treatment is proposed for several separate wastewater streams, the interaction of which may have a significant effect on treatability or even on composition. Mathematical prediction of the interactions among chemical components may be inaccurate or impossible and testing a suitable integrated sample may provide useful information. Both lakes and reservoirs show spatial variations of composition (depth and horizontal location). However, there are conditions under which neither total nor average results are especially useful, but local variations are more important. In such cases, examine samples separately (i.e., do not integrate them). Preparation of integrated samples usually requires equipment designed to collect sample water uniformly across the depth profile. Knowledge of the volume, movement, and composition of the various parts of the water being sampled usually is required. Collecting integrated samples is a complicated and specialized process that must be described in a sampling plan.

### 3.3 Characteristics of wastewater

The characteristics of wastewater can be classified as

1. Physical characteristics

2. Chemical characteristics
3. Biological characteristics

### 3.3.1 Physical characteristics of wastewater

**Colour:** Fresh domestic sewage is grey, with the passage of time as putrefaction starts, it begins to get black.

**Odour:** Normal fresh sewage has a musty odour which is normally not offensive, but as it starts to get stale, it begins to give offensive odour. Within 3-4hrs, all the oxygen present in the sewage gets exhausted and it starts emitting offensive odour of hydrogen sulphide gas & other sulphur compounds produced by anaerobic micro-organisms.

**Temperature:** Generally the temperature of wastewater is higher than that of the water supply due to addition of warm water from the households & from industries. When the wastewater flows in closed circuits, its temperature rises further. Average temperature of wastewater in India is around 20<sup>0</sup>C, which is quite close to the ideal temperature for the biological activities.

**Turbidity:** It is a measure of light-emitting properties of wastewater & turbidity test is used to indicate the quality of waste discharges w.r.t colloidal matters. The turbidity depends upon the strength of the sewage.

**Solid content:** Sewage normally contains 99.9% of water & 0.1% of solids. Total solids in wastewater exist in 3 forms:

1. Suspended solids
2. Dissolved solids
3. Colloidal Solids

### 3.3.2 Chemical characteristics of wastewater

**pH value:** The test for pH value of wastewater is carried out to determine whether it is acidic or alkaline. A high concentration of either an acid or alkali in wastewater is indicative of industrial wastes.

**Chloride content:** Chloride in natural water result from the leaching of chloride containing rocks & soils with which the water comes in contact. Chlorides found in domestic sewage is derived from kitchen wastes, human faeces & urinary discharges.

**Nitrogen Contents:** Nitrogen appears as

1. Ammonia Nitrogen or Free Ammonia: It is the very first stage of decomposition of organic matter. It exists in aqueous solution as either ammonium ion or ammonia depending upon the pH.
2. Organic Nitrogen: It is determined by Kjeldahl method. The sum of organic & ammonia nitrogen is called Total Kjeldahl nitrogen
3. Albuminoid Nitrogen: The quantity of nitrogen present in wastewater before the decomposition of organic matter is started. It indicates the amount of under composed nitrogenous material in the wastewater.
4. Nitrites Nitrogen: Nitrites indicate the presence of partly decomposed organic matter.
5. Nitrates Nitrogen: Nitrates indicate the presence of fully oxidized organic matter.

**Fats, grease & oils:** It is mainly contributed from kitchen wastes like butter, vegetable oils & fats. It is also discharge from industries like garages, workshops, factories etc. They interfere with biological action & cause maintenance problems.

**Surfactants:** It comes primarily from synthetic detergents. They are discharge from bathrooms, kitchens, washing machines etc.

**Phenols, pesticides & agricultural chemicals:** Phenols are found in industrial wastewater, if it is directly discharged into the rivers it causes serious taste problems in drinking water. Pesticides, agricultural chemicals result from surface runoff from agricultural, vacant, park lands.

**Toxic Compounds:** Copper, lead, silver, chromium, arsenic, boron (Toxic cations), Cyanides, chromates (Toxic anions) etc results from industrial wastewaters.

**Sulphates, Sulphides and H<sub>2</sub>S gas:** Sulphates & sulphides are formed due to decomposition of various sulphur containing substances present in wastewater. Anaerobic bacteria chemically reduce sulphates to sulphides and to H<sub>2</sub>S.

**Other gases:** carbon-di-oxide, methane, Hydrogen sulphide, ammonia, nitrogen, oxygen are the common gases found in untreated wastewater.

**Oxygen Consumed:** It is the oxygen required for the oxidation of carbonaceous matter.

**Dissolved Oxygen:** It is the amount of oxygen in the dissolved state in the wastewater. Wastewater generally does not have DO, its presence in untreated wastewater indicated that the wastewater is fresh.

### 3.3.3 Biological characteristics of wastewater

The biological characteristics of sewage are related to the presence of micro-organisms.

1. Aquatic plant
2. Aquatic animals
3. Aquatic bacteria and viruses

**Anaerobic processes:** Decomposition of organic matter is called putrefaction & the result is called liquefaction as the solid organic matter is dissolved by enzymes. Anaerobic bacteria oxidize organic matter utilizing electron acceptors other than oxygen. In carrying out their metabolic process they produce CO<sub>2</sub>, H<sub>2</sub>O, H<sub>2</sub>S, CH<sub>4</sub>, NH<sub>3</sub>, N<sub>2</sub>, reduced organics & more bacteria. Treatment units which work on putrefaction alone are septic tanks, imhoff tanks and sludge digestion tanks.

**Aerobic Processes:** The work of the aerobic bacteria i.e. combination with oxygen is called oxidation. Aerobic bacteria utilize free oxygen as an electron acceptor. The end products of aerobic activity are CO<sub>2</sub>, H<sub>2</sub>O, SO<sub>4</sub>, NO<sub>3</sub>, NH<sub>3</sub> and more bacteria.

Though each of the above two processes work in opposite direction the former by splitting up & the latter by building up, there is co-ordination between two. In the first stage, the anaerobic bacteria decompose complex organic matter into simple organic compounds while in the second stage; the aerobic bacteria oxidize them to form stable compounds.

### 3.4 Flow diagram of Municipal wastewater treatment plant



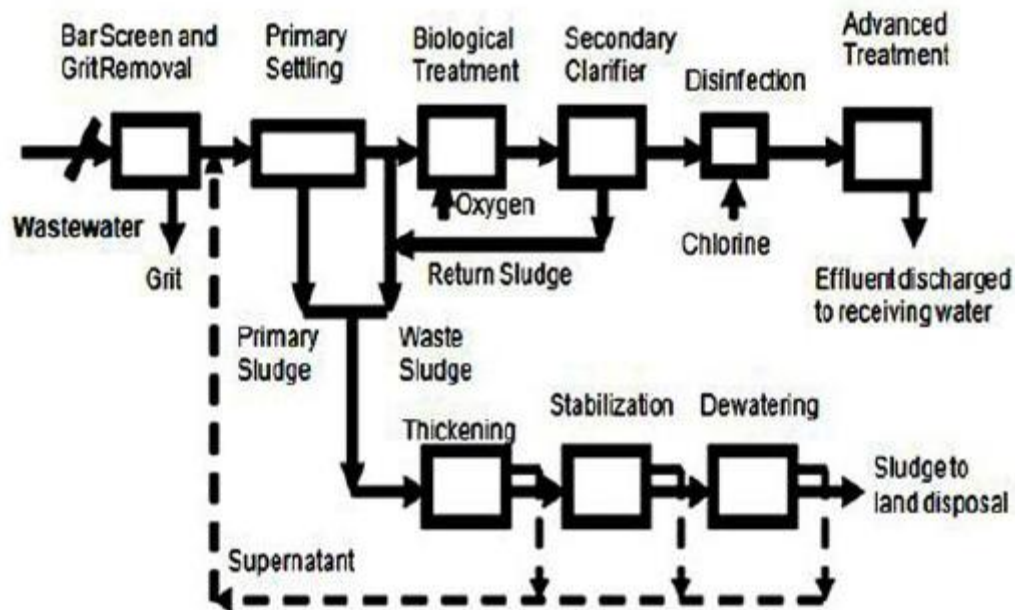

The influent or wastewater collected from residences or industries are first subjected to **Screening** process to remove the floating matters present in the sewage. The water which comes out of screening tanks is passed through the **Grit chambers** or **Detritus tanks** to remove the grits or sand particles. Then effluent which comes out of grit chamber is subjected to **Primary Sedimentation tanks** in order to remove the large suspended organic solids which is achieved by settling process where water is allowed to flow in slower rate, then heavy denser particles settles down at the bottom of the tank. The settled organic particles at the bottom of the primary sedimentation tanks is called **primary sludge**. The effluent which comes out of the primary settling tank is subjected to **Biological treatment or Secondary treatment** where, decomposition of organic matter takes place by aerobic bacteria with the supply of oxygen. Then stabilized organic particles along with the water is passed through the **Secondary clarifier** where the stabilized organic particles settle at the bottom of the tank. The sludge which is settled at the bottom of the tank is again recirculated back and mixed with effluent which comes from primary sedimentation tank which is part of **Activated Sludge Process** and remaining sludge is mixed with primary sludge and then subjected to **Sludge digestion process**. In sludge digestion process, wastewater is first subjected to **Thickening**, where number of solid sludge particles are increased by separating from liquid. The liquid which rests over the solid sludge particles is removed out and is called as supernatant. The solid sludge which consists of moisture content is removed out in **Dewatering process**. The dry form of sludge is used as manure for improving the fertility of soil. The effluent which comes out of secondary clarifier is fed into disinfection tank where chlorine is added to the wastewater to kill germs and pathogenic bacteria present in the water. Then water which comes out of disinfection tank containing germs is removed out in final or advanced or tertiary treatment process after that, the water can be directly discharged to nearby water courses.

**Treatment process as a whole classified into 4 types**

- 1) Priliminary treatment process
- 2) Primary treatment process
- 3) Secondary or Biological treatment process
- 4) Tertiary or final or advanced treatment process

**3.4.1 Priliminary treatment process:** This treatment process consists of separating the floating materials like dead animals, tree branches, papers, pieces of rags or wood etc., present in the sewage and also to remove heavy settalable inorganic solids. This process also helps in removing oil and grease particles present in the sewage. This process reduces the BOD of wastewater by about 15 to 30%.

The units used in priliminary process are

- a) **Screening** - For removal of floating matters like papers, rags, pieces of clothes etc.
- b) **Grit chambers or Detritus tank** – For removal of grits and sand particles.
- c) **Skimming tanks** – For removal of oil and grease particles present in the sewage.

**3.4.2 Primary treatment process:** This treatment process consists of removing large suspended organic solids. This is usually achived by **sedimentation process**. The liquid effluent from primary treatment process consists of large amount of suspended organic matters having BOD of 60% of original. The organic solids which are separated out in the sedimentation tank are often stabilized by anaerobic decomposition in a digestion tank. This residue is used for land fills or soil conditioners.

**3.4.3 Secondary treatment process:** This treatment process further treats the effluent which is coming out from primary sedimentation tanks. This treatment process is achived by biological decomposition of organic matter which can be carried out either under aerobic or anaerobicv condition.

Treatment process in which organic matter is decomposed by aerobic bacteria is called aerobic decomposition. Units which are used in this treatment process are

- a) **Filters** – Intermetant sand filters as well as trickling trickling filters. Intermittent sand filters are used for treatment of wastewater by attaching micoorganisms to the filter medium and treated water is collected in the underdrains at the bottom of sand filter and is transported to a line for further treatment or disposal. Trickiling filters are used to remove organic matter from wastewater. Trickling filter is an aerobic treatment system that utilizes microorganisms attached to the medium to remove organic matter from wastewater.
- b) **Aeration tanks** – Wastewater is is mixed with microbes in the aeration tank and oxygen is supplied. Microbes consume that supplied oxygen and decomposes the organic matter present in the wastewater and thus water is cleaned.
- c) **Oxidation ponds** – Oxidation ponds are also known as stabilization ponds or lagoons. Within an oxidation pond heterotropic bacteria degrade organic matter in the sewage which



results in production of cellular material and minerals. The production of these support the growth of algae in the oxidation pond.

d) **Aerated lagoons:** Aerated lagoons or aerated basins is a holding and treatment pond provided with artificial aeration to promote the biological decomposition of wastewater.

Treatment process in which organic matter is decomposed anaerobic bacteria is called **anaerobic decomposition**. Units which are used in this treatment process are,

a) **Anaerobic lagoons:** These are also called as manure lagoon which are man made earthen basins filled with animal waste that undergoes anaerobic decomposition and it will be converted into excellent manures.

b) **Septic tanks:** These are water-tight box made of concrete or fibre glass to separate solids and liquids by settling process.

c) **Imhoff tanks:** These types of tanks are used for reception and processing of sewage which is achieved by sedimentation along with anaerobic sludge digestion.

The effluent from the secondary biological treatment will usually contain a little BOD of 5 to 10% of original.

**3.4.4 Final or Advanced or Tertiary treatment process:** This process removes remaining organic load after secondary treatment and to kill pathogenic bacteria present in the sewage and this achieved by chlorination

### **3.5 Unit operations:**

**3.5.1 Screening:** Screening is the first and essential step in the treatment of sewage. It consists of passing sewage through different sized screens to trap and remove comparatively large size of floating matters. If such floating matters are not removed they may damage pumps and mechanical equipments, and it will interfere with the satisfactory operation of the treatment units.

Screen is device with openings generally of uniform size for removing bigger suspended or floating matters in sewage. The screening element may consists of parallel bars, gratings or wire meshes or perforated plates and the openings may be of any shape, although generally they are circular or rectangular.

Screen should be situated preferably just before grit chambers, and they are housed in a chamber called screen chamber. These screens are always set in an inclined position with an angle of about 30° to 60° with vertical. This increases the effective screening surface by 40 to 100% and helps in preventing the excessive loss of head due to clogging.

#### **Types of screens**

Screens may classified as follows:

1) **According to size of openings** – coarse, medium and fine screens.

- 2) **According to shape of screens** – disc, band, drum, cage, wing and perforated plates.
- 3) **According to the condition of movement** – fixed and movable.
- 4) **According to the method of cleaning** – hand cleaned or mechanically.

**According to size of openings:**

**Coarse Screen:** These type of screens are also called as **Racks or Bar screens**. They have relatively larger openings ranging from 5cm to 10cm. They serve more as protecting devices in contrast to fine screens with function as treatment devices. Bar screens are usually hand cleaned.

**Medium Screens:** These type of screens have openings of 2cm to 5cm. These are mechanically raked units, and used before all pumps or treatment units such as stabilization ponds.

**Fine Screens:** These type of screens are mechanically cleaned devices using perforated plates or very closely spaced bars with clear openings of less than 2cm and they need continuous cleaning to prevent clogging.

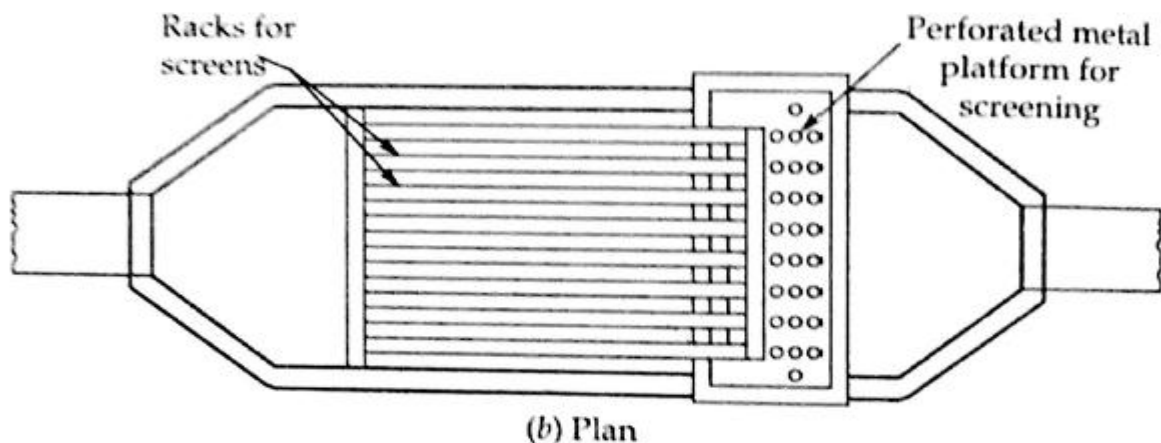
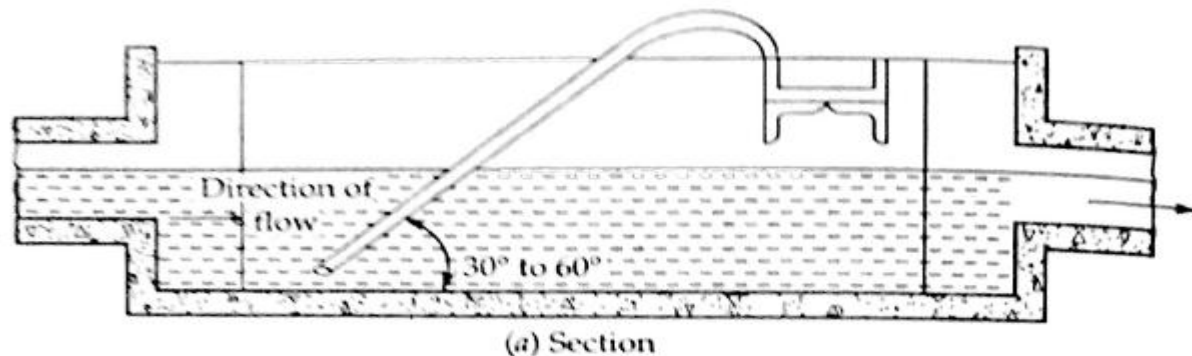

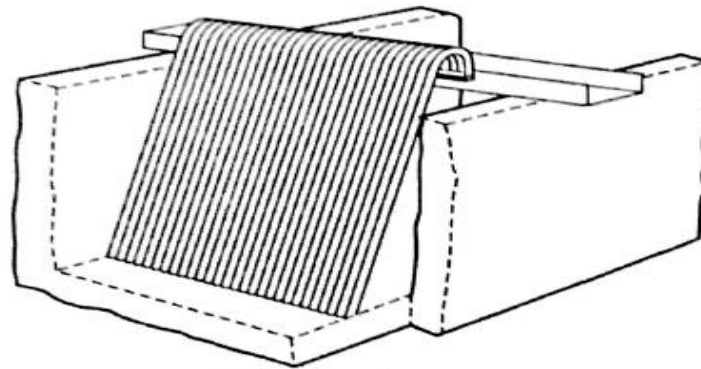

(c) Prospective view

Fig. 9.2. Fixed Bar type Hand Cleaned Coarse or Medium Screen or Rack.

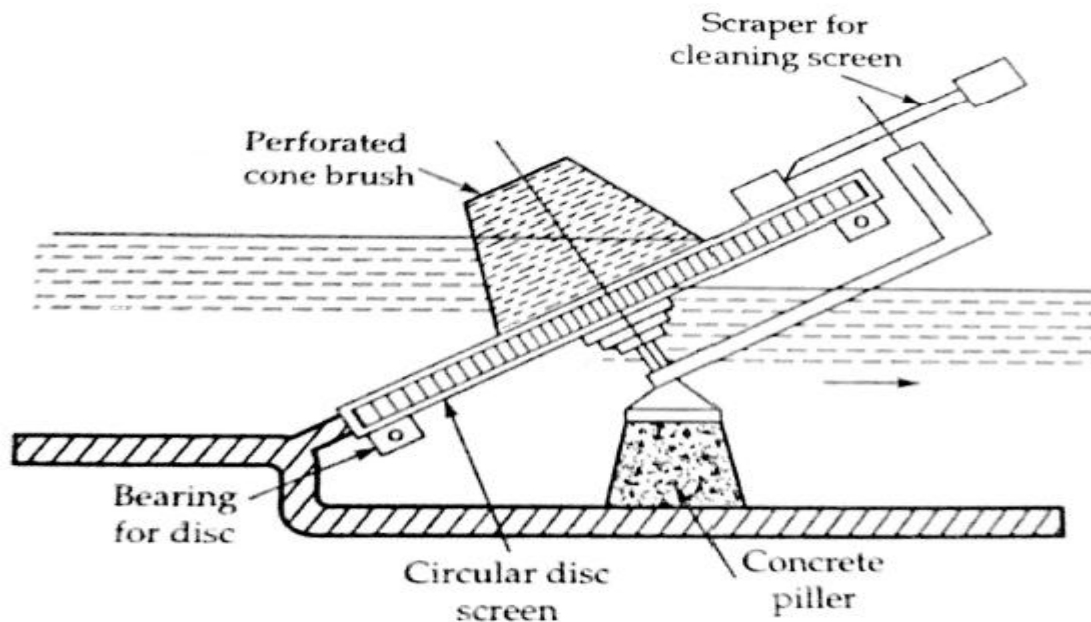

Fig. 9.3. Reinsch-Wurl screen (disc type fine screen).

**According to shape of screens:** These screens are usually fine screens and are available in different forms as mesh screen, band screen, perforated plate screen, wing screen, drum screen, disc screen, cage screen etc.

**According to the condition of movement:**

**Fixed screens** are permanently set in position and must be cleaned by **rakes** pulled between the bars.

**Movable screens** are stationary when in operation, but are lifted from the sewage for the purpose of cleaning.

Screen chambers are wide open channels which are provided with smooth entrance and exit. At its entry point, it should be narrow enough to keep the minimum approach velocity of flow

at a self-cleansing value and should be wide enough at its exit point to keep the maximum velocity from dislodging the accumulated slope.

**3.5.2 Grit chambers:** Grit includes sand and other heavy matters which are inert inorganic such as metal fragments, rags etc. If not removed in preliminary treatments, grit in primary settling tank can cause abnormal abrasive wear and tear on mechanical equipments and sludge pumps, can clog by deposition and can accumulate in sludge holding tanks and digesters. Therefore grit removal is necessary to protect the moving mechanical equipment and pump elements from abrasion.

Grit removal devices depends upon the differences in specific gravity between organic and inorganic solids to effect their separation.

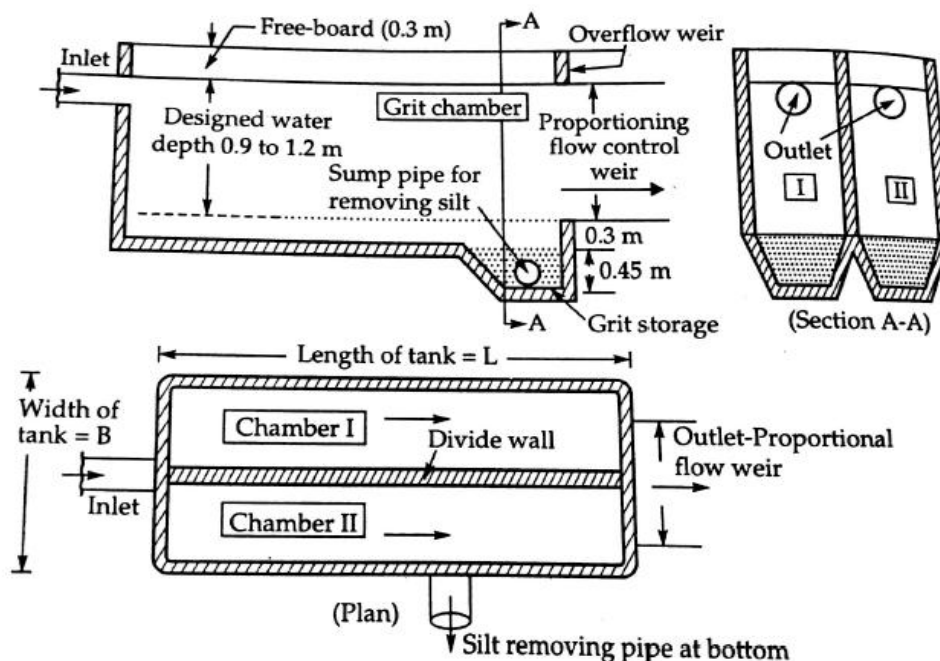

### Types of Grit chambers:

Grit chambers are of two types, mechanically cleaned and manually cleaned. Mechanically cleaned grit chambers are provided with mechanical equipment for collection and washing of grit chambers, which are operated either on a continuous or intermittent basis. Manually operated grit chambers should have sufficient capacity for storage of grits between the intervals of cleaning.

**Aerated Grit chambers:** An aerated grit chamber is a special form of grit chamber consisting of a standard spiral flow aeration tank provided with air diffusion tubes placed at one end of the tank at about 0.6 to 1m from the bottom. The heavier grit particles with their higher settling velocities drop down to the floor, where as lighter organic particles will remain in suspension and carried with the roll of spiral motion due to the diffused air and eventually carried out of the tank.

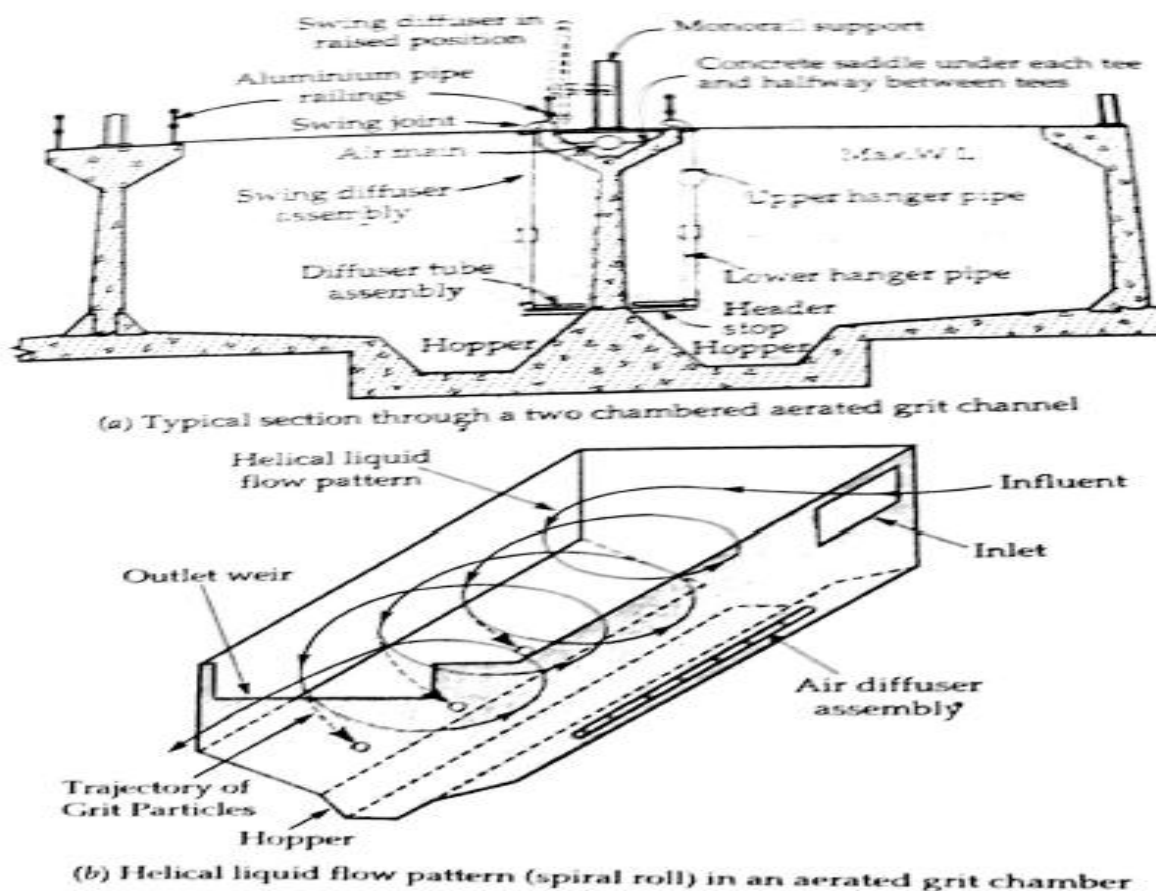

Fig. 9.9. Aerated grit chamber.

**3.5.3 Oil and Grease removal:** Oil and grease, if not removed, may create the following difficulties.

- 1) If sewage is being discharged into the water bodies for disposal, unsightly scum will be formed at the surface and foul odour is prevalent around the natural water bodies. The scum retards re-oxygenation and thus causes anaerobic conditions.
  - 2) They do not digest easily and therefore create problems in sludge digestion tanks.
  - 3) They promote clogging of filter material of the trickling filters.
  - 4) They affect the biological activities of the organisms and thus affect their smooth working.
- The oil and grease particles may be removed by floatation or settling as scum or sludge. Formation of scum is promoted by diffusing air through the sewage. The tank in which scum formation is promoted by air diffusion through the sewage is called **Skimming tanks**.

**Skimming tank:** Skimming tanks are narrow rectangular tanks having at least two longitudinal baffle walls interconnected. They are used to remove grease and fatty oils from the sewage. Air diffusers are provided at the bottom of the tank. Compressed air applied at the rate varying from 300 to 6000m<sup>3</sup>/million litres of sewage agitates the sewage, which prevents settling of solids. Air tends to change the oil and grease to a soapy mixture. This mixture is carried to the surface by the air bubbles, some of which are entrained in it and may be skimmed off.



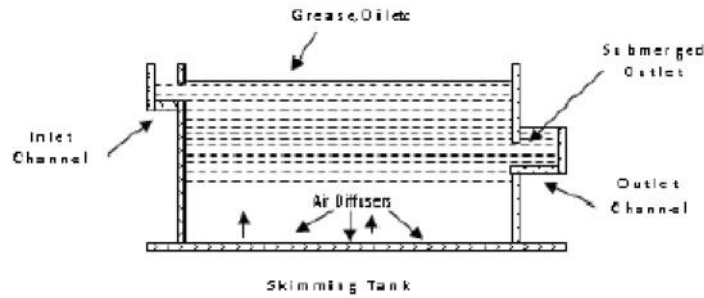

### 3.6 Trickling filters

Trickling filters are adopted for giving secondary treatment to sewage. It consists of tanks of coarser filtering medium, over which the sewage is allowed to sprinkle or trickled down by means of spray nozzles or rotary distributors. The percolating sewage is collected at the bottom of the tank through a well designed under drainage system. The purification of the sewage is brought about mainly by the aerobic bacteria, which form a bacterial film around the particles of the filtering medium. The action due to the mechanical straining of the filter bed is much less. In order to ensure the large scale growth of the aerobic bacteria, sufficient quantity of oxygen is supplied by providing suitable ventilation facilities in the body of the filter and also to some extent by the intermittent functioning of the filter.

The effluent obtained from the filter must be taken to the secondary clarifier for the settling out the organic matter, oxidized while passing down the filter.

#### Flow sheet of a trickling filter system

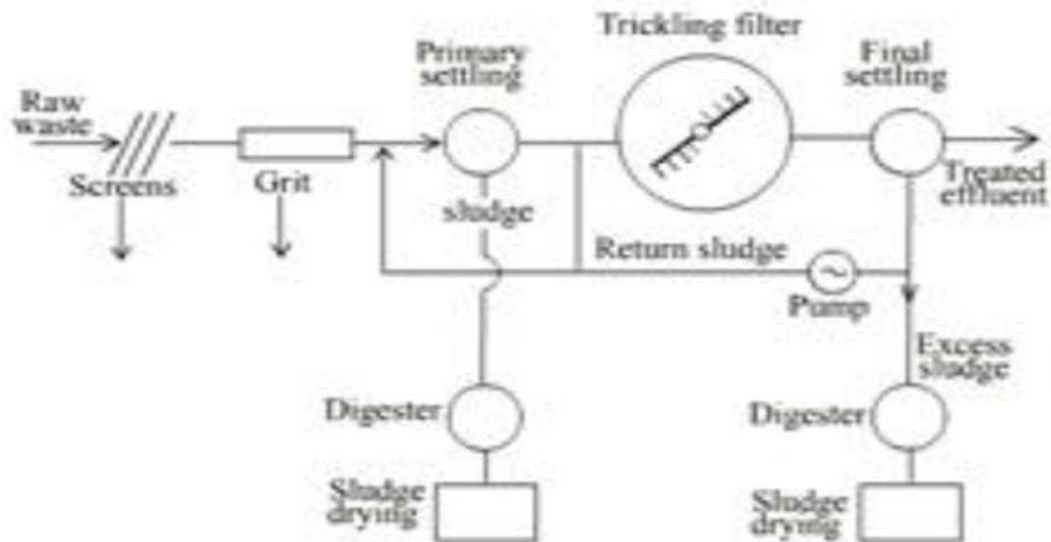

#### Construction and operation:

Trickling filter tanks are generally constructed above the ground. They may either be rectangular or more generally circular.

Rectangular filters are provided with a network of pipes having fixed nozzles, which spray the incoming sewage into the air, which then falls over the bed of the filter under the action of gravity.

Circular filter tanks are provided with rotary distributors having a number of distributing arms (generally 4 nos). These distributors rotate around a central support either



by an electric motor or more generally by the force of reaction on the sprays. Such self-propelled reaction type of distributors is now-a-days preferred and used. The rate of revolutions varies from 2 RPM for small distributors to  $< \frac{1}{2}$  RPM for large distributors. Two arms are used for taking low flows and all 4 arms are used in case of high flows. The distributing arms should remain about 15 to 20cm above the top surface of the filtering medium in the tank.

The application of the sewage to the filter is practically continuous with a rotary distributor, where as with spray nozzles, the filter is dosed for 3 to 5min and then rested for 5 to 10min before the next application. The dosing tanks are used in case of spray nozzles method.

The filtering medium consists of coarser materials like cubically broken stones or slag free from dust or small pieces of stones. The size varies from 25 to 75mm. The filtering material should be washed before it is placed in position and it should be unaffected by acidic action of sewage and should be sufficiently hard. Usually strong form rocks of granite or limestone may be used. The depth of filtering medium may vary from 2 to 3m. The walls of the filter tank should be provided with openings for the circulation of air through.

The under drainage system below the filter bed provides drainage and also ventilation of the sewage. These systems are made of vitrified clay blocks which are placed on a concrete thickness of 10 to 15cm thick and which is sloped gently at about 1 in 300 towards the main effluent rectangular channel. The main effluent channel may be provided adjoining the central column of the distributor. The depth and width of this central channel should be such that, maximum flow is carried below the level of the under drains.

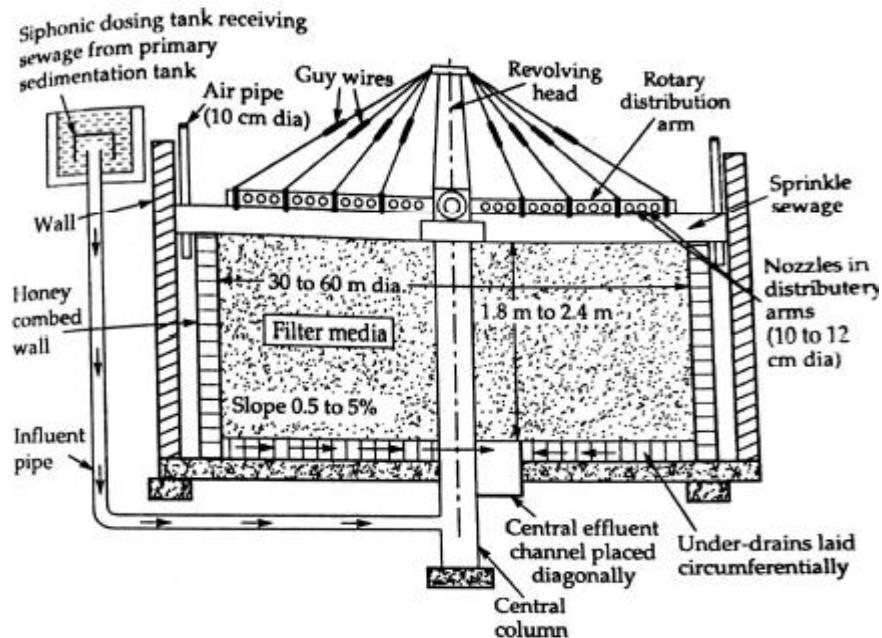

Fig. 9.18(a) Typical section of a conventional Circular-Trickling filter with Rotary distributors (vertical scale shown enlarged).

### Design of trickling filters

Design of trickling filters involves the design of diameter of the circular filter tank, its depth, the design of rotary distributor and under-drainage system.

1. Design of filter size is based upon the values of the filter loading – 22 to 44 million litres per hectare per day.

2. Organic loading rate – 900 to 2200 kg of BOD<sub>5</sub> per ha-m.

With an assumed value of organic loading, we can find out the total volume of the required filter by dividing the total BOD<sub>5</sub> of the sewage entering the filter per day in kg, by the assumed value of the organic loading. The organic loading can thus decide the volume of the filter.

The hydraulic loading rate of the other hand gives us the area of the filter required; when the total sewage volume entering the filter per day is divided by the hydraulic loading. Knowing the volume and the area of the cylindrical filter, we can easily find out its dia and depth.

### 3.7 Activated Sludge Process (ASP)

Activated sludge refers to biological treatment processes that use a suspended growth of organisms to remove BOD and suspended solids and process requires an aeration tank and a settling tank.

The activated sludge process was developed in England in 1914 and was so named because it involved the production of an activated mass of microorganisms capable of aerobically stabilizing the organic content of a waste. Activated sludge is probably the most versatile of the biological treatment processes capable of producing an effluent with any desired BOD. The process has thus found wide application among domestic wastewater and industrial wastewater treatment.

#### Flow diagram of Activated Sludge Process (ASP)

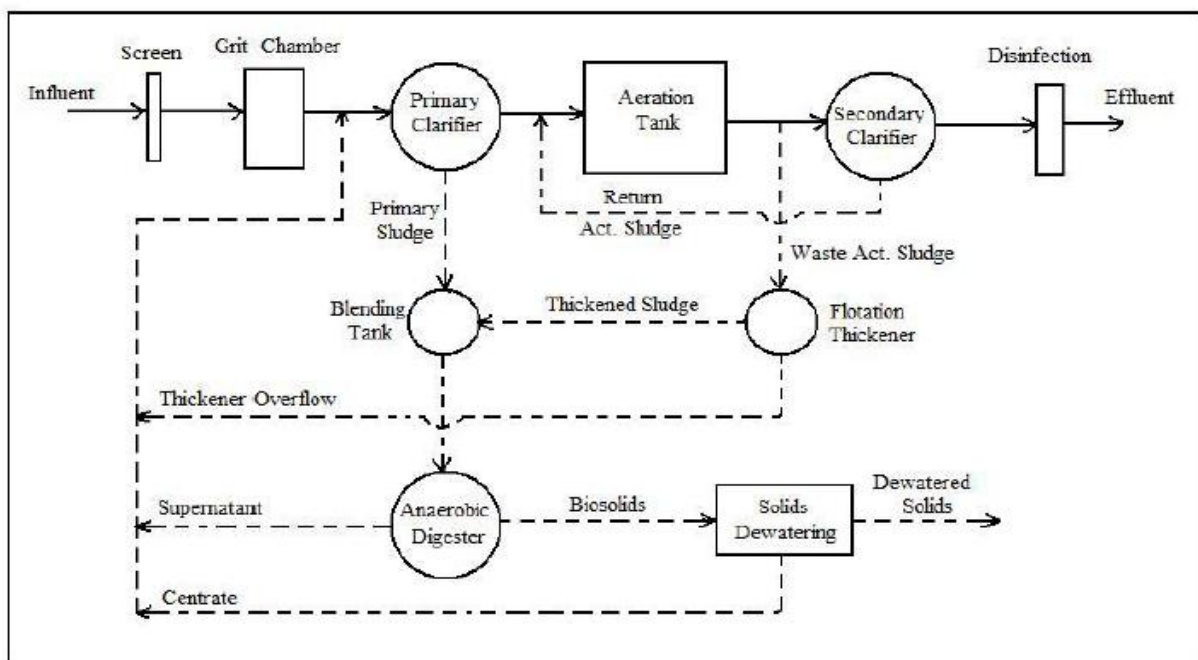

Primary effluent is mixed with return activated sludge to form mixed liquor. The mixed liquor is aerated for a specified length of time. During the aeration the activated sludge organisms use the available organic matter as food producing stable solids and more

organisms. The suspended solids produced by the process and the additional organisms become part of the activated sludge. The solids are then separated from the wastewater in the settling tank. The solids are returned to the influent of the aeration tank (return activated sludge). Periodically the excess solids and organisms are removed from the system (waste activated sludge). Failure to remove waste solids will result in poor performance and loss of solids out of the system over the settling tank effluent weir.

**Factors affecting ASP** There are a number of factors that affect the performance of an activated sludge treatment system. These include:

- temperature
- return rates
- amount of oxygen available
- amount of organic matter available
- pH
- waste rates
- aeration time
- wastewater toxicity

To obtain desired level of performance in an activated sludge system, a proper balance must be maintained between the amounts of food (organic matter), organisms (activated sludge) and oxygen (dissolved oxygen).

#### **Advantages of Sludge process**

1. It gives clear and non-putrescible effluent.
2. The process is free from offensive odour.
3. The process requires limited land area.
4. The sludge has commercial value.

#### **Disadvantages of Sludge process**

1. The process requires skilled personnel, careful supervision for design, operation and maintenance.
2. It gives poor results for shock loads and fluctuations in the effluent
3. The volume of the sludge produced is large and difficulties arise during dewatering of sludge.
4. It requires more initial investment.

### **3.8 Sequential batch reactors**

The operation of an SBR is based on a fill-and-draw principle, which consists of five steps- fills, react, settle, draw, and idle. These steps can be altered for different operational applications.

**Fill:** During fill, the influent wastewater is added to the biomass that was left in the tank from the previous cycle. It may be either the raw wastewater or the primary effluent. The length of the fill period depends on the number of SBRs, the volume of the SBRs, and the nature of the

flow of the wastewater source, which can be intermittent or continuous. Depending upon the treatment objective, the fill may be static, mixed or aerated

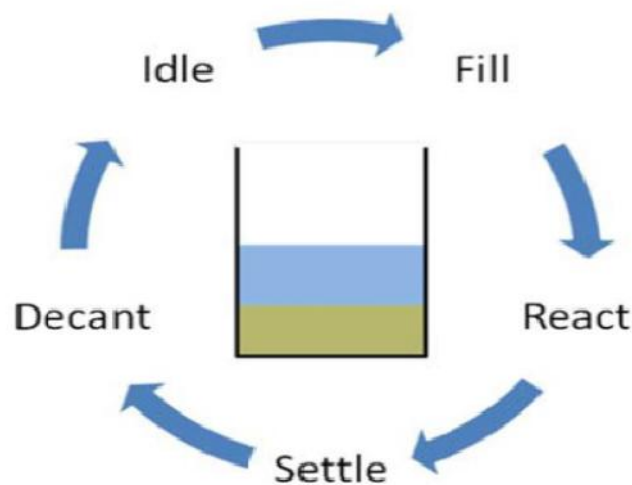

**React:** During the react phase, biomass consumes the substrate under controlled environmental conditions (aerobic, anaerobic) depending on wastewater treatment. During aerated react, the organic matter oxidation and nitrification take place. If the mixed reaction is applied, denitrification can be attained. Anaerobic conditions can also be achieved in the mixed react mode for phosphorus removal. The time dedicated to react can be as high as 50% or more of total cycle time

**Settle:** In the SBR, solids separation takes place under quiescent conditions (i.e., without inflow or outflow) in a tank, which may have a volume more than ten times that of the secondary clarifier used for conventional continuous-flow activated sludge plant. Quiescent conditions developed give rise to the better solid separation than that of conventional clarifiers. This phase normally lasts between 0.5 and 1.5 hours to avoid the solids blanket from floating due to gas build-up.

**Draw:** After the settle phase, the clarified supernatant is discharged from the reactor as effluent. The withdrawal mechanism may take one of several forms, including a pipe fixed at some predetermined level with the flow regulated by an automatic valve or a pump, or an adjustable or floating weir at or just beneath the liquid surface. In any case, the withdrawal mechanism should be designed and operated in a manner that prevents floating matter from being discharged. The time dedicated to draw can range from 5 to more than 30% of the total cycle time. The time in Draw, however, should not be overly extended because of possible problems with rising sludge.

**Idle:** The period between draw and fill is termed as idle. This phase is most necessary when SBR is used with a continuous wastewater flow. This time can be effectively used to waste sludge.

### 3.9 Moving bed bio reactors

The Moving Bed Biofilm Reactor (MBBR) is a highly effective biological treatment process that was developed on the basis of conventional activated sludge process and bio-filter process. It is a completely mixed and continuously operated Biofilm reactor, where the

biomass is grown on small carrier elements that have a little lighter density than water and are kept in movement along with a water stream inside the reactor. The movement inside a reactor can be caused by aeration in an aerobic reactor and by a mechanical stirrer in an anaerobic or anoxic reactor.

MBBR possesses many excellent traits such as high biomass, high COD loading, strong tolerance to loading impact, relatively smaller reactor and no sludge bulking problem. There are presently more than 400 large-scale wastewater treatment plants based on this process in operation in 22 different countries all over the world. During the past decade it has been successfully used for the treatment of many industrial effluents including pulp and paper industry waste, poultry processing wastewater, cheese factory wastes, refinery and slaughter house waste, phenolic wastewater, dairy wastewater and municipal wastewater. Recently, Moving Bed Biofilm Reactor (MBBR) has brought increasing research interest in practice for removal of biodegradable organic matter and its application has undergone various degrees of modification and development. Moreover, as the carrier using in the MBBR is playing a crucial role in system performance, choosing the most efficient carrier could enhance the MBBR performance. Hence, scientists have been looking for an appropriate carrier which is not costly and has a suitable surface for microbial growth. The main aim of this study is to evaluate a specific MBBR with polyethylene media as Biofilm support carrier in terms of OMs removal along with nutrient removal and microbial growth and activity.

#### Advantage of Moving Bed Biofilm Processes

1. Compact units with small size.
2. Increased treatment capacity.
3. Complete solids removal.
4. Improved settling characteristics.
5. Operation at higher suspended biomass
6. Concentrations resulting in long sludge retention times.
7. Enhanced process stability.

#### 3.10 Sludge digesters:

A sludge digestion tank is a RCC or steel tank of cylindrical shape with hopper bottom and is covered with fixed or floating type of roofs.

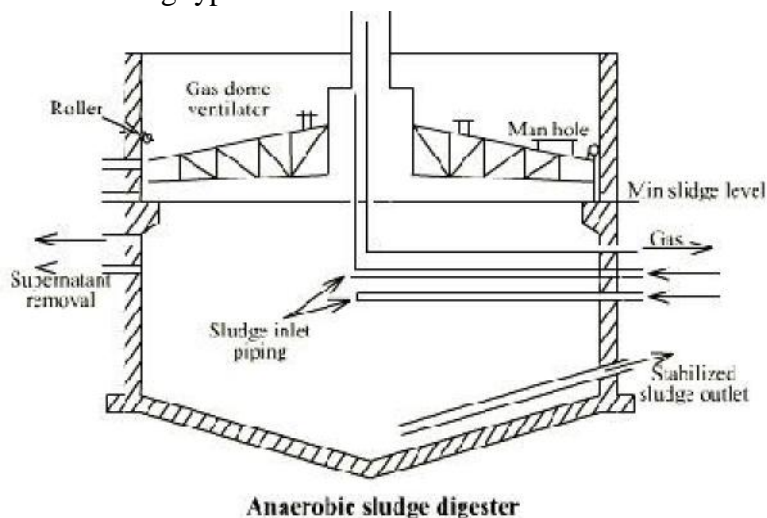

### Types of Anaerobic Digesters

The anaerobic digesters are of two types: standard rate and high rate. In the standard rate digestion process, the digester contents are usually unheated and unmixed. The digestion period may vary from 30 to 60 d. In a high rate digestion process, the digester contents are heated and completely mixed. The required detention period is 10 to 20 d.

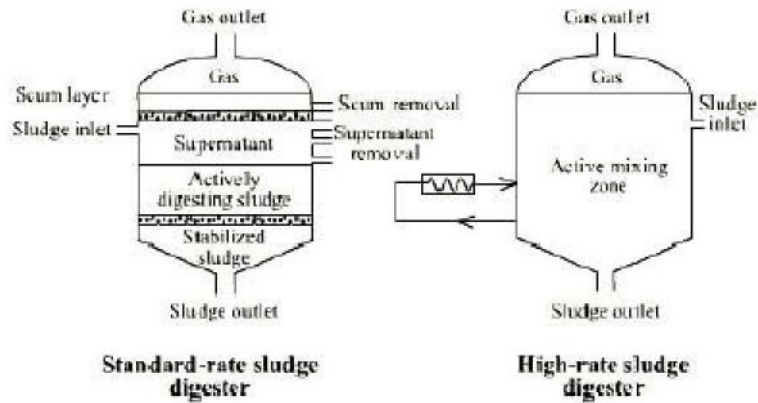

Often a combination of standard and high rate digestion is achieved in two-stage digestion. The second stage digester mainly separates the digested solids from the supernatant liquor: although additional digestion and gas recovery may also be achieved.

### 3.11 Recommended Questions

1. Define sampling. Explain the methods of sampling.
2. With flow diagram explain the municipal waste water treatment
3. Write a note on grit chamber and skimming tank.

### 3.12 Outcomes

- Evaluate degree of treatment and type of treatment for disposal, reuse and recycle.

### 3.13 Further Reading

1. [https://www.researchgate.net/publication/298346182\\_Biological\\_Treatment\\_Processes\\_Suspended\\_Growth\\_vs\\_Attached\\_Growth](https://www.researchgate.net/publication/298346182_Biological_Treatment_Processes_Suspended_Growth_vs_Attached_Growth)
2. <https://www.slideshare.net/jshrikant/sludge-management-and-sludge-digesters>
3. [https://www.dsd.gov.hk/rdforum/2014/ppt/Presentation\\_\(B4-1\).pdf](https://www.dsd.gov.hk/rdforum/2014/ppt/Presentation_(B4-1).pdf)
4. [https://www.mae.gov.nl.ca/waterres/training/aww/08\\_susheel\\_sequencing\\_batch\\_reactors\\_in\\_wastewater\\_treatment.pdf](https://www.mae.gov.nl.ca/waterres/training/aww/08_susheel_sequencing_batch_reactors_in_wastewater_treatment.pdf)